

## 5G Wireless Communication Systems

Saddam Hossain

*Department of Electronics & Telecommunication Engineering, The People's University of Bangladesh (PUB)  
Bangladesh*

**Abstract:** - As a subscriber becomes more aware of the mobile phone technology, he/she will seek for an appropriate package all together, including all the advanced features of a cellular phone can have. Hence, the search for new technology is always the main intention of the prime cell phone giants to out innovate their competitors. In addition, the main purpose of the fifth generation wireless networks (5G Wireless networks) is planned to design the best wireless world that is free from limitations and hindrance of the previous generations. 5G technologies will change the way most high bandwidth users access their Mobile Radio Communication (MRC). So, this paper represents, great evolution of 1G (First Generation) to 4G yield 5G, introduction to 5G technologies, why there is a need for 5G, advantages of 5G networks technology, exceptional applications, Quality of Service (QoS), 5G network architecture-The MasterCore as well as hardware and software for the 5G MasterCore technology.

**Keywords:** - 5G, All IP Network, Cloud Computing , 5G architecture-The MasterCore, Quality of Service (QoS), 5G-IU, Parallel Multimode (PMM).

### I. INTRODUCTION

We are living in modern science. We can not think a single moment without science. Science makes our life easy and comfortable. Modern world is being compressed due to the development of science and its technologies. During the last few decades, the world has seen phenomenal changes in the telecommunications industry due to science and technology. We have different mobile and wireless communication technologies, which are mass deployed, such as WiMAX (IEEE 802.16 wireless and mobile networks) , Wi-Fi (IEEE 802.11 wireless networks), LTE (Long Term Evolution), 3G mobile networks (UMTS, cdma2000) and 4G as well as accompanying networks, such as personal area networks (e.g., Bluetooth, ZigBee) or sensor networks. Mobile terminals include variety of interfaces, such as GSM is one, which are based on old-fashioned circuit switching, the technology that is going into its last decade of existence. These technologies (mainly cellular generations) differ from each other based on four main aspects: radio access, data rates, bandwidth and switching schemes [1]. These differences have been noticed in previous generations (1G, 2G, 2.5G and 3G etc.). In accordance to, we are exploring the most advance cellular technology, could be 5G.

5G Technology stands for 5th Generation Mobile Technology. 5G technology has changed to use cell phones within very high bandwidth. 5G is a packet switched wireless system with wide area coverage and high throughput. 5G technologies use CDMA and BDMA and millimeter wireless that enables speed is greater than 100Mbps at full mobility and higher than 1Gbps at low mobility. The 5G technologies include all types of advanced features which make 5G technology most powerful and in huge demand in the near future. It is not amazing, such a huge collection of technology being integrated into a small device. The 5G technology provides the mobile phone users more features and efficiency. A user of mobile phone can easily hook their 5G technology gadget with laptops or tablets to acquire broadband internet connectivity. Up till now following features of the 5G technology have come to surface- High resolution is offered by 5G for extreme mobile users, it also offers bidirectional huge bandwidth [2], higher data rates and the finest Quality of Service (QoS) (i.e. discussed below in the paper).

Now a days, all wireless and mobile networks are forwarding to all-IP principle, that means all data and signaling will be transferred via IP (Internet Protocol) on network layer [3].The purpose of the All-IP Network (AIPN) is to completely transform ("to change in composition or structure") the 100+ years of legacy network

infrastructure into a simplified and standardized network with a single common infrastructure for all services [15]. In order to implement 5G technology, MasterCore technique is needed to apply All-IP Network (AIPN) properly. Hence, the Mastercore is designed. The 5G MasterCore is a convergence of Parallel Multimode (PMM), Nanotechnology, Cloud Computing, and All IP Platform (Broadly mansion in section....) also 5G-IU technology. These technologies have their own impacts on existing wireless networks which make them into 5G.

## II. EVOLUTION OF WIRELESS TECHNOLOGIES

This section mentions in short the evolution of wireless and cellular systems based on the four main key aspects: radio access, data rates, bandwidth and switching schemes.

### 2.1 Review of Previous Fourth Generations Systems

#### 2.1.1 First-Generation Systems (1G)

The 1st generation was pioneered for voice service in early 1980's, where almost all of them were analog systems using the frequency modulation technique for radio transmission using frequency division multiple access (FDMA) with channel capacity of 30 KHz and frequency band was 824-894 MHz [6], which was based on a technology known as Advance Mobile Phone Service (AMPS).

#### 2.1.2 Second Generation Systems (2G)

The 2nd generation was accomplished in later 1990's. The 2G mobile communication system is a digital system; this system is still mostly used in different parts of the world. This generation mainly used for voice communication also offered additional services such as SMS and e-mail. In this generation two digital modulation schemes are used; one is time division multiple access (TDMA) and the 2nd is code division multiple access (CDMA) [7] and frequency band is 850-1900 MHz. In 2G, GSM technology uses eight channels per carrier with a gross data rate of 22.8 kbps (a net rate of 13 kbps) in the full rate channel and a frame of 4.6 milliseconds (ms) duration [14]. The family of this generation includes of 2G, 2.5G and 2.75G.

#### 2.1.3 Third Generation Systems (3G)

Third generation (3G) services combine high speed mobile access with Internet Protocol (IP)-based services. The main features of 3G technology include wireless web base access, multimedia services, email, and video conferencing. The 3G W-CDMA air interface standard had been designed for "always-on" packet-based wireless service, so that computer, entertainment devices and telephones may all share the same wireless network and be connected internet anytime, anywhere [13]. 3G systems offer high data rates up to 2 Mbps, over 5 MHz channel carrier width, depending on mobility/velocity, and high spectrum efficiency. The data rate supported by 3G networks depends also on the environment the call is being made in; 144 kbps in satellite and rural outdoor, 384 kbps in urban outdoor and 2Mbps in indoor and low range outdoor [4]. The frequency band is 1.8 - 2.5 GHz [16].

#### 2.1.4 Fourth Generation Systems (4G)

4G usually refers to the successor of the 3G and 2G standards. In fact, the 3GPP is recently standardizing LTE Advanced [8] as future 4G standard. A 4G system may upgrade existing communication networks and is expected to provide a comprehensive and secure IP based solution where facilities such as voice, streamed multimedia and data will be provided to users on an "Anytime, Anywhere" basis and at much higher data rates compared to previous generations. One common characteristic of the new services to be provided by 4G is their demanding requirements in terms of QoS. Applications such as wireless broadband access, Multimedia Messaging Service (MMS), video chat, mobile TV, HDTV content and Digital Video Broadcasting (DVB) are being developed to use a 4G network.

##### 2.1.4.1 LTE advanced

LTE release 10, also referred to as LTE-Advanced, is claimed to be the true 4G evolution step. Earlier releases of LTE are included as integrated parts of LTE release 10, providing a more straightforward backwards compatibility and support of legacy terminals, for example. The main requirement specification for LTE advanced as approved in [8] are:

- Peak Downlink data rate: 1 Gbs, Peak Uplink data rate: 500 Mbps.
- Transmission bandwidth: Wider than approximately 70 MHz in DL and 40 MHz in UL.
- User throughput at cell edge 2 times higher than that in LTE.
- Average user throughput is 3 times higher than that in LTE.
- Spectrum efficiency 3 times higher than that in LTE; Peak spectrum efficiency downlink: 30 bps/Hz, Uplink: 15 bps/Hz.
- Mobility: Same as that in LTE.
- Coverage should be optimized or deployment in local areas/micro cell environments with Inter Site Distance (ISD) up to 1 km.

III. FIFTH GENERATION SYSTEMS (5G)

5G Wireless Communication System is not deployed yet. The big challenge for the design and deployment of 5G wireless system can be faced easily as proposed features and architecture (mentioned below) that will increase system capacity and quality within the limited available frequency spectrum, whose frequency band and Data Bandwidth will be ‘3-300GHz’ and ‘1Gbps & higher (as demand)’ successively. The remarkable issue, there don’t have any limitation in 5G as respect to user demands in the next 200 years. The 5G also implies the whole wireless world interconnection (WISDOM—Wireless Innovative System for Dynamic Operating Mega communications concept), together with very high data rates of the Quality of Service (QoS) applications.

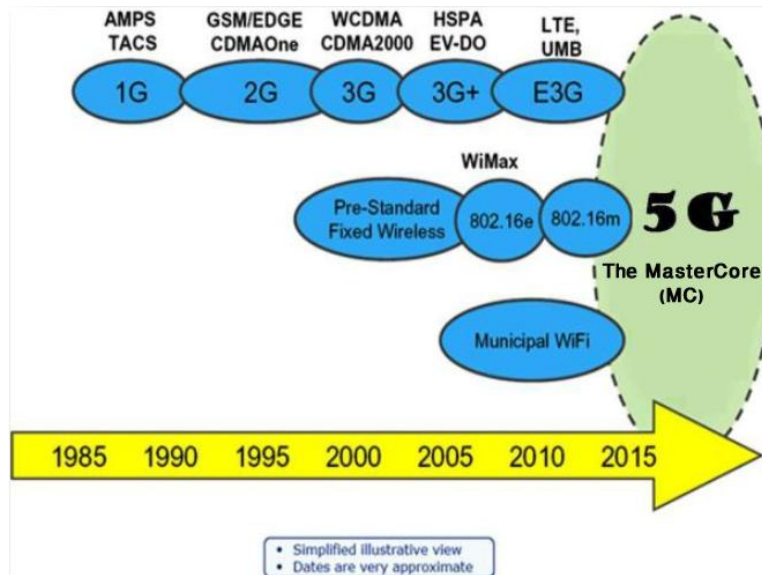

Figure 1: Evolution of Mobile Technologies

Table 1: Basic comparison among 3G, 4G and 5G Technology

Technology/features	3G	4G	5G
Data Bandwidth	2Mbps	2Mbps to 1Gbps	1Gbps & Higher (as demand)
Frequency Band	1.8 - 2.5 GHz [16]	2 - 8 GHz [16]	3-300GHz [16],[18]
Standards	WCDMA CDMA-200 TD-SCDMA [19]	All access convergence including:OFMDA,MC-CDMA Network-LMPS [19]	CDMA & BDMA
Technology	Broad bandwidth CDMA,IP technology [19]	Unified IP And seamless combination of broadband LAN/WAN/PAN and WLAN [19];	Unified IP and seamless combination of broadband, LAN/WAN/PAN/WLAN [19] and technologies for 5G new deployment (could be OFDM etc.);
Service	Integrated high quality audio, video and data	Dynamic information access, wear-able devices, HD streaming; global roaming;	Dynamic information access, wear-able devices, HD streaming; any demand of users; upcoming all technologies; global roaming smoothly;
Multiple Access	CDMA	CDMA	CDMA & BDMA
Core Network	Packet Network	All IP Network	Flatter IP Network & 5G Network Interfacing(5G-NI)
Definition	Digital Broadband, packet data	Digital Broad band, Packet data, All IP	Digital Broadband, Packet data All IP, Very high throughput
Hand off	Horizontal	Horizontal & Vertical	Horizontal & Vertical
Start from	2001 [12]	2010 [12]	2015 [12]

### 3.1 Why is there a need for 5G?

This paper mainly focuses on how a 5G network can provide more facilities approach to a common man to utilize his available possessions in an enormous way to make him to feel the real progress. As a user point of view, the major difference between current generations and expected 5G techniques must be something else than increased maximum throughput; other requirements include [1]:

- It could make better revenue for current global operators as well as interoperability will become more feasible.
- Improved and innovative data coding and modulation techniques, which includes filter bank multi carrier way in schemes.
- For wireless access and back haul use of millimeter wave frequencies is very useful.
- With the support of different conduction points with related coverage and surrounding the option of a supple usage of resources for up link and down link transmission in each cell is achieved by superior intrusion and mobility management.
- To make 5G practical for all sorts of radio access technologies there should be a common platform unique for all the technologies.
- Lower battery consumption.
- Lower outage probability.
- Better coverage and high data rates available at cell edge.
- Multiple concurrent data transfer paths.
- Possible to 1Gbps and higher data rate in mobility.
- More secure; better cognitive radio/SDR Security.
- Higher system level spectral efficiency.
- World Wide Wireless Web (WWWW), wireless-based web applications that include full multimedia capability beyond 4G speeds.
- More applications combined with Artificial Intelligent (AI) as human life will be surrounded by artificial sensors which could be communicating with mobile phones.
- Not harmful to human health.
- Cheaper traffic fees due to low infrastructure deployment costs.
- Smart beam antenna systems.

5G is to be a new technology that will provide all the possible applications, by using only one universal device, and interconnecting most of the already existing communication infrastructures. The 5G terminals will be an upgradable multimode and cognitive radio- enabled. It will have software defined radio modulation schemes. All the required upgradable software should be downloaded from the Internet on the run. The 5G mobile networks will focus on the development of the user terminals where the terminals will have access to different wireless technologies at the same time and will consolidate various flows from various technologies. Besides, the terminal will make the ultimate choice among different wireless/mobile access network providers for a given service.

### 3.2 Advantages of 5G network of the MasterCore technology

The MasterCore technology has been designed for boundless wireless service; so that computer, entertainment devices and mobile phone may all share the same wireless network and can be connected with internet anytime, anywhere. It's designed for 5G communication system to fulfill the limitless target up to the next two centuries, the common features as following;

- Files can be downloaded (even movies) within seconds.
- Pages will upload almost instantly.
- Can play easily online games.
- 5G devices are comparatively less expensive than 3G and 4G devices.
- Using 5G the battery runs out very fast.
- Finest Quality of Service (QoS).
- All Networks can be gathered on a platform.
- Easily support previous generations.
- New deployments of 5G can be connected directly with The Mastercore by 5G -IU (5G Interfacing Unit) without All IP concept.
- No limitation as user demands.
- Ability to support the new services.

- World combination services are available.
- The MasterCore's hardware and software are upgradeable.
- Able to fill user's demand up to next century.
- Subscribers can store data in central storage.
- Remote PCs can be controlled by handsets.
- Subscriber can use application software without installation in own devices that provided by the MasterCore.
- Security is distributed several layers.
- The MasterCore can manage all securities of PSTNs, MSC, and BTS etc.
- The high quality services of 5G technology based on Policy to avoid error.

### 3.2.1 Quality of Service (QoS)

Next Generation Networks (NGN) consists of support functionalities for data transport, and control transport, as well as functionalities for support of services and applications. The measurement of traffic is a basic control activity in order to provide Quality of Service, [5]. In addition 5G communication system is designed by the finest Quality of Service (QoS).

Quality of Service (QoS) refers to a network's ability to achieve maximum bandwidth and deal with other network performance elements like latency, error rate and uptime. Quality of service also involves controlling and managing network resources by setting priorities for specific types of data (video, audio, files) on the network. QoS is exclusively applied to network traffic generated for video on demand, IPTV, VoIP, streaming media, videoconferencing and online gaming. The primary goal of quality of service is to provide priority to networks, including dedicated bandwidth, controlled jitter, low latency and improved loss characteristics. Its technologies supply the elemental building blocks that will be used for future business applications in campus, wide area networks and service provider networks. There are three fundamental components for basic QoS implementation [17]:

- Identification and marking techniques for coordinating QoS from end to end between network elements.
- QoS within a single network element.
- QoS policy, management, and accounting functions to control and administer end-to-end traffic across a network.

### 3.3 Exceptional applications

The 5G MasterCore has some exceptional applications with common features as;

- One can know weather, temperature, and location etc. of each other when conversation is going on.
- Students can attend any class of any institute of the world without going there (by WCSM).
- A doctor can treat patients of other countries from a place.
- Possible to monitor any place of the world from anywhere.
- Batteries can be charged by using network without charger.
- It could be possible to visualize lively all the planets and the Universe.
- One can complete his/her works without going to the office.
- One can be able to locate his/her child when she/he is unfortunately missed.
- One can be able to predict tsunami/earthquake before it occurs.

### 3.4 A proposed 5G Network Architecture

Terminals and network components are dynamically upgraded (and adapted) to new situation. Network operators use the upgradeability to introduce value-added services more easily. Upgradeability is based on cognitive radio. Cognitive radio technologies include the ability of devices to determine their location and location's information (i.e. temperature, weather etc.), sense spectrum used by neighboring devices, change frequency, adjust output power and even alter transmission parameters and characteristics. A cognitive radio is a transceiver (beam) that is able to understand and respond to its operating environment. Thus cognitive radio concerns mobile devices and networks which are computationally intelligent about radio resources and related communications to explore user communication needs and provide wireless services, be appropriate to those needs. Hence, the radio is aware and cognitive about changes in its environment and responds to these changes by adapting operating characteristics in some way to improve its performance. In addition, the appropriate proposed architecture of the 5G MasterCore technology is shown below in figure 2.

#### 3.4.1 The MasterCore

The 5G potential will require the design of a single wireless user terminal able to self-explanatory operate in different heterogeneous access networks.

A fully upgradable terminal changes its communication functions depending on network and/or user demands. In addition, the main challenge for an upgradable MasterCore is to deal with increasing number of different radio access technologies based on solid interoperability criteria and mechanisms. A core could be a convergence of the aforementioned nanotechnology, Parallel Multimode (PMM) technology, cloud computing and cognitive radio, upgradable and based on All IP Platform and 5G-IU is called the MasterCore. The 5G MasterCore is an upgradable and multi-technologies core. The MasterCore upgradability could be a self-adaptation and made adaptation to a dynamically-changing environment or mission oriented adaptation to meet a given set of mission requirements with the aim of improving service delivery and spectrum utilization. The MasterCore changes its communication functions depending on network status and/or user demands. Upgradability could be in both software and hardware. Hardware upgradability is mainly performed by operators, adding additional equipments to increase network capacity at a specific time. However, in software upgradability and with the power of SDR, network is dynamically upgradable, which means that the programs (running on the upgradable processing elements) as well as the communication links between the processing elements are upgraded at run-time. Upgradable hardware and software segments have been shown in the MasterCore Technology (MCT) in Figure 3. Different processing elements are used for different purposes. The general purpose processors are fully programmable to perform different computational tasks. The block diagram of the MasterCore architecture is shown in Figure 2.

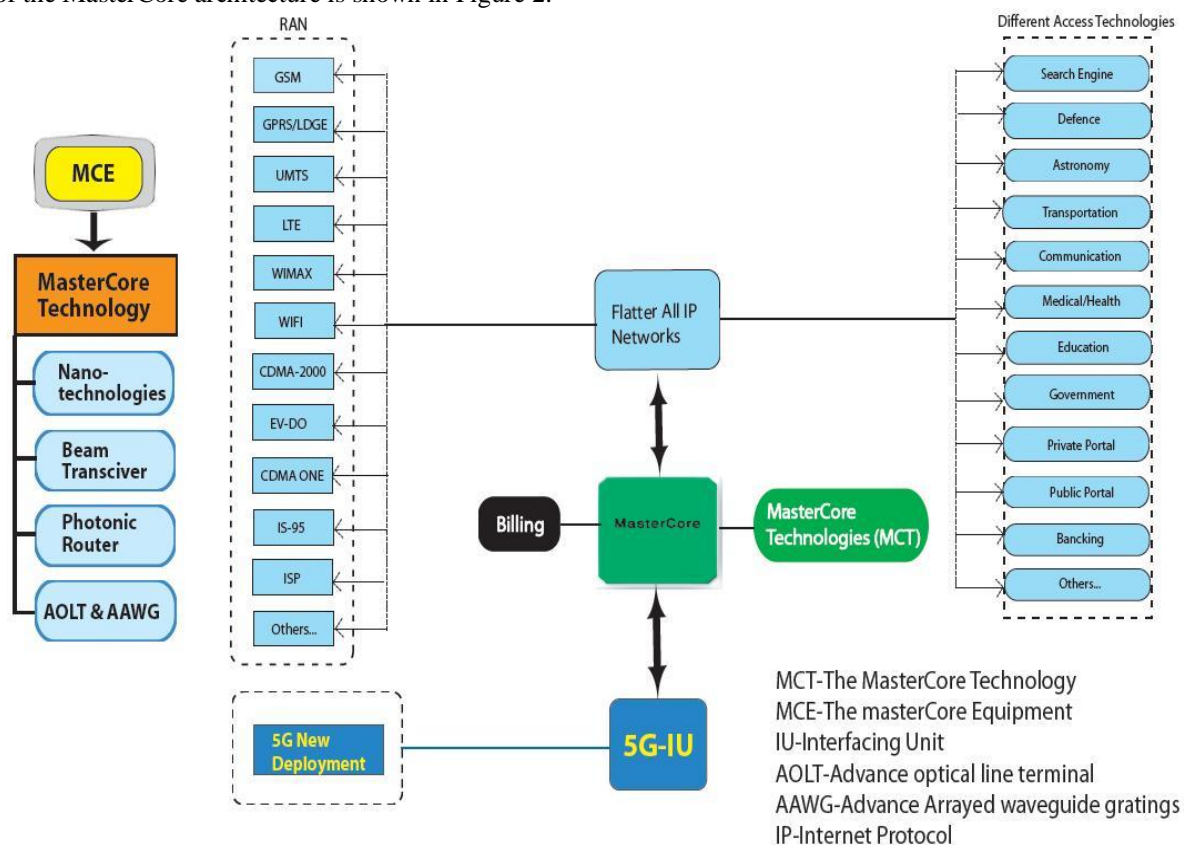

Figure 2: The MasterCore Architecture

### 3.4.2 The MasterCore Technologies (MCT)

The 5G MasterCore is a convergence of below mention technologies. These technologies have their own impact on exiting wireless network which makes them in to 5G. The different segments of the MasterCore Technology (MCT) are displayed below in figure 3.

#### 3.4.2.1 Parallel Multimode (PMM)

In 5G Wireless Communication Systems, The MasterCore can be operated into parallel multimode such as All IP Network Mode, 5G Network Mode, where in All IP Network Mode controls all network technologies of RAN and DAT (Different Access Networks) up to 5G new deployments. 5G Network Mode manages all new deployments based on 5G as a result 5G network systems will be more efficiency, powerful and less complicated. Any service mode can be opened under 5G-NDM (New Deployment Mode) as WCSM (World Combination Service Mode).WCSM provides some services among subscribers that can be used in special purposes for example, a lecturer writes on white board that display on another board without video in

any country of the world and vice versa besides conversation and video. For Parallel Multimode, any new service can be added easily so that system of the network no needs to change. In fact all modes run at a time continuously (i.e. parallel).

### 3.4.2.2 All IP Network

The All-IP Network (AIPN) is an evolution of the 3GPP system to fulfill the increasing demands of the cellular communications market. It is a common platform valid for all sorts of radio access technologies. AIPN focused primarily on the enhancements of packet switched technology but now it provides a continued evolution and optimization in terms of both performance and cost. The key benefits of AIPN architecture includes a variety of different access systems' provision, lower costs, universal seamless access, and increased user-satisfaction and reduced system latency. But with the advantages of IP come some dangers: as data flow more freely and the internet is open not only to developers but also to all manner of criminals and viruses, developers and operators face new security challenges which should be solved properly.

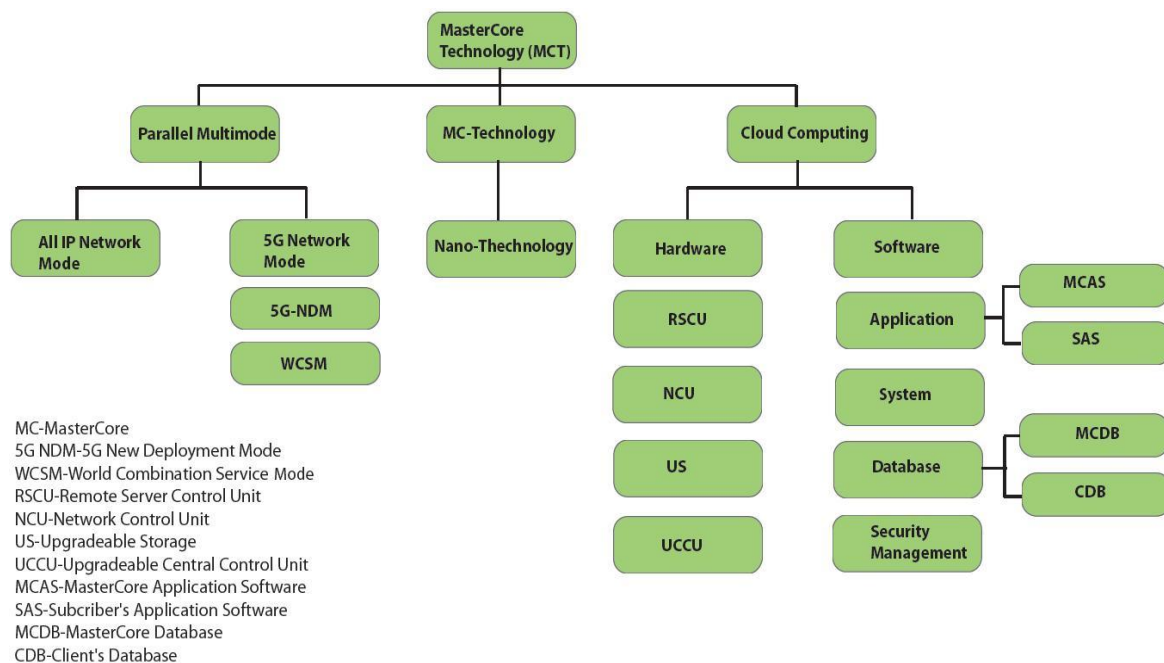

Figure 3: Segments of the MasterCore Technology (MCT)

### 3.4.2.3 Nanotechnology

Nanotechnology is the application of nanoscience to control process on nanometer scale between 0.1 to 100nm. The field is also known as Molecular Nanotechnology (MNT) where MNT deals with control of the structure of matter based on atom-by-atom and molecule by molecule engineering. Nanotechnology is considered as the next industrial revolution, and the telecommunications industry will be radically transformed by it in a few years. As the future applications will require more memory and computing power to offer higher data rates, current technologies can not resolve these challenges. Fortunately, nanotechnology could provide effective solutions for power efficient computing, sensing, memory enlargement, and human-machine interaction, [9], [10].

Nanotechnology has shown its impact on both mobile as well as the core network as follows.

- The mobile device has become more than a communication device in modern world; computation and communication are ready to serve the user in an intelligent way. Mobile devices together with the intelligence, embedded in human environments, will create a new platform that enables ubiquitous sensing, computing, and communication. With nanotechnology mobile phones can act as intelligent sensors that have applications in many industries, among them transportation, communications, medicine and safety.
- The core network requires high speed and a reliable capacity to manipulate and interoperate increasing number of heterogeneous access technologies. At present, nanotechnologies are used in Digital Signal Processing (DSP) Fabrication, introducing new perceptions in DSP designing that increases the overall system speed & capacity.

Apart from this it has its own impact on sensor as well as security. This is considered as a most significant in telecommunication.

#### 3.4.2.4 Cloud computing

“Cloud computing is a model for enabling ubiquitous, convenient, on-demand network access to a shared pool of configurable computing resources (e.g., networks, servers, storage, applications, and services) that can be rapidly provisioned and released with minimal management effort or service provider interaction...” a definition from [11]. Hence, cloud computing is a technology that uses the internet and central remote server to maintain data and applications. In 5G networks this central remote server could be a content provider. Cloud computing allows consumers and business to use applications without installation and access their personal files at any computer with internet access. The same concept is going to be used in multi-core technology where the user tries to access his private account from a global content provider through cloud computing.

### 3.5 MC Hardware and Software

#### 3.5.1 Hardware

In MasterCore technology, assembly of hardware is set into several units to maintain whole network system properly, also to troubleshoot in core network instantly.

As a result, efficiency of the core is suitable with demanded services. Hardware classified into different units as:

- a) Remote Server Control Unit (RSCU) provides a great opportunity to control remote server of users' networks. It indicates the immediate condition of remote server.
- b) Network Control Unit (NCU) provides control of the communications among MS, BSC, MSC and PSTN.
- c) Upgradeable Storage (US) refers to increase the storage as necessity as demand.
- d) Upgradeable Central Control Unit (UCCU) provides the facilities to control all units centrally.

#### 3.5.2 Software

Software Defined Radio (SDR) benefits from today's high processing power to develop multi-band, multi-standard base stations and terminals. Although in future the terminals will adapt the air interface to the available radio access technology, at present this is done by the infrastructure. Several infrastructure gains are expected from SDR. For example, to increase network capacity at a specific time (e.g. during a sports event), an operator will reconfigure its network adding several modems at a given. Base Transceiver Station (BTS). SDR makes this reconfiguration easy. In the context of 4G systems, SDR will become an enabler for the aggregation of multi-standard pico/micro cells. For a manufacturer, this can be a powerful aid to providing multi-standard, multiband equipment with reduced development effort and costs through simultaneous multi-channel processing.

1) 5G will be single unified standard of different wireless networks, including wireless technologies (e.g. IEEE 802.11), LAN/WAN/ PAN and WWW, unified IP and seamless combination of broad band.

2) Software Defined Radio, Packet layer, implementation of packets, encryption, flexibility etc. In figure 2 are shown different classification segments of 5G software such as:

**a) Application:** The MasterCore Application Software (MCAS) refers to all application software are needed as to provide services and managements.

Subscriber's Application Software (SAS) is installed centrally so that subscriber runs a program without installing on his own devices. All services of application software are provided from central server.

**b) System:** System Software is an Operating System (OS) for the 5G MasterCore networking.

**c) Database:** The MasterCore Database (MCDB) software refers to manage and store all data of whole system those are needed. Client's Database (CDB) software manages all data of user's server those contain all essential information of users and users' networks.

**d) Security Management:** Securities (users to the Mastercore) will be managed centrally by Security Management (SM) software.

### 3.6 5G-IU

5G-IU (5G Interfacing Unit) acts to make the most powerful of 5G wireless communication system. Because, all sorts of radio access technologies are combined in a common platform is complex form of aggregation. It will be more complex in future when added new radio access technologies. This is why, 5G-IU is used between new deployments and core network so that 5G wireless communication system is easily manageable. It has some advantages are:

- Lower costs to establish networks.
- Lessen equipments.
- Improve network efficiency.
- Reduce complexity.
- Easily maintain high security.
- Impossible to occur any trouble.

### 3.7 The MasterCore Equipments (MCE)



Mobile phone has become more than a communication device in modern world it has turned into an identity of an individual. In 5G MasterCore these mobile and other devices (Laptop, local networking devices etc.) are referred as the MasterCore Equipments (MCE) as they are improved with nanotechnology, Beam Transceiver, Advance Optical Line Terminal (AOLT), Advance Arrayed Waveguide Gratings (AAWG). Nanotechnology refers NanoEquipments (NE) are Morph, Graphene's Transistor, GPS, Micro-Micro Phones, Liquid lens, Intelligent Batteries and Nanosensor [4]. We will broadly discuss about NE in our further papers. These are classified into two categories one is user's device and another is internal devices of user's networks. AOLT and AAWG are used in user's networks (LAN, WAN, MAN etc.) to increase faster data rate. We will be discussing about AOLT and AAWG in our further slides. One of the central visions of the wireless industry aims at ambient intelligence, computation and communication always available and ready to serve the user in an intelligent and efficient way. This requires that the devices are mobile. Mobile devices together with the intelligence and efficient that will be embedded in human environments – home, office, public places – will create a new platform that enables ubiquitous sensing, computing, and communication Specs of MasterCore Equipments given as follow:

- Self Cleaning – the phone cleans by itself.
- Self powered – the phone derives its energy/power from the sun, water, or air.
- Sense the environment – the phone will tell you the weather, the amount of air pollution present, etc.
- Flexible – bend but not break.
- More Reliable.
- Transparent – “see through” phones.

#### IV. FUTURE ENHANCEMENT

5G network technology will reveal a new era in mobile communication technology. The 5G mobile phones will have access to different wireless technologies at the same time and the terminal should be able to combine different flows from different technologies. 5G technology offer high resolution for crazy cell phone user. 5G technology will provide supper and perfect utilization of cellular communication in future. We can monitor any place of the world from anywhere, observe space and watch TV channels at HD clarity in our mobile phones without any interruption. There will be exciting amusement unbelievable services. The 5G mobile phones will be a tablet PC and amazing. Many mobile embedded technologies will evolve.

#### V. CONCLUSION

In this paper we have discussed the existing and future wireless mobile communication generations and cellular systems focusing on four main key factors: switching schemes, bandwidth, data rates, and radio access, also 5G main development challenges and explained the necessity for 5G. The 5G mobile technology will be implemented at the end of the current decade. We have proposed the MasterCore technology and its hardware and software implementation. We expect that this Paper helps to uplift stronger links between people working in different fields creating future concepts of mobile communication, Internet services, Quality of Service (QoS), Cloud computing, All IP network, Nanotechnologies and concept of the MasterCore. The new coming 5G technology is available in the market to fulfill user demands in affordable rates, bright and high peak future also much reliability as well as exceptional applications.

#### REFERENCES

##### Books, Journal Papers or Theses:

- [1] Dr. Anwar M. Mousa, “Prospective of Fifth Generation Mobile Communications” *International Journal of Next-Generation Networks (IJNGN) Vol.4, No.3, September 2012*
- [2] Sapana Singh & Pratap Singh, “Key Concepts and Network Architecture for 5G Mobile Technology” *International Journal of Scientific Research Engineering & Technology (IJSRET) Volume 1 Issue 5 pp 165-170 August 2012*
- [3] T. Janevski, “Traffic Analysis and Design of Wireless IP Networks”, *Artech House Inc., Boston, USA, 2003.*
- [4]. Imthiyaz Ali, “5G the Nanocore” *March 5, 2011*
- [5] ITU-T, Y.2173, “Management of performance measurement for NGN”, *September 2008.*
- [6] Chen, YP; Yang, YH (2007), “A new 4G architecture providing multimode terminals always best connected services,” *IEEE Wireless Communications, Volume: 14 Issue: 2 pp. 36-41.*
- [7] Xichun Li, AbudullaGani, RosliSalleh, Omar Zakaria 2009,” *The Future of Mobile Wireless Communication Networks, ”2009 International Conference on Communication Software and Networks*
- [8] 3GPP TSG RAN TR 36.913 v8.0.0, *Requirements for Further Advancements for E-UTRA (LTEAdvanced).*

- [9] Ermolov V. et al. "Significance of Nanotechnology for future wireless devices and Communications", *The 18th Annual IEEE International Symposium on PIMRC'07*.
- [10] R.K.Jain, Risal Singh, "Role of Nanotechnology in future wireless and communication systems", *National seminar proceeding, Academy of Business & Engineering Science Ghaziabad, pp-19-28, 16-17th January 2009*.
- [11] Peter Mell and Timothy Grance, "The NIST Definition of Cloud Computing" *US National Institute of Standards and Technology Special Publication 800-145, September 2011*.
- [12] Engr. Muhammad Farooq, Engr. Muhammad Ishtiaq Ahmed, Engr. Usman M Al, "Future Generations of Mobile Communication Networks" *Academy of Contemporary Research Journal V II (I), 15-21, ISSN: 2305-865, January 2013*
- [13] Theodore S. Rappaport, "Wireless Communications Principle and Practice," published by Pearson Education (Singapore) Pte. Ltd., Second Edition, Chapter Two;
- [14] Vijay K. Garg and Joseph E. Wilkes, "Principles & Applications of GSM," Published by Doplting Kindersley (India) Pvt. Ltd., licensees of Pearson Education in South Asia, First Impression, 2006;

**URL:**

- [15] <http://ytd2525.wordpress.com/category/all-ip-networks/>
- [16] <http://www3.nd.edu/~mhaenggi/NET/wireless/4G/#3G%20Vs%204G%20>
- [17] <http://www.techopedia.com/definition/9049/quality-of-service>
- [18] <http://spectrum.ieee.org/telecom/wireless/millimeter-waves-may-be-the-future-of-5g-phones>
- [19] <http://www.slideshare.net/noorec786/generations-of-network-1-g-2g-3g-4g-5g>

Let's go ahead.....**To be continued.....**