

American Journal of Engineering Research (AJER)

e-ISSN : 2320-0847 p-ISSN : 2320-0936

Volume-02, Issue-10, pp-481-500

www.ajer.org

Research Paper

Open Access

Cold nuclear fusion

Huang Zhenqiang Huang Yuxiang

Nuclear force constraint inertial guidance cold nuclear fusion Collide and ion speed dc transformer**1 Technology**

In normal temperature condition, the nuclear force constraint inertial guidance method, realize the combination of deuterium and tritium, helium and lithium... And with a magnetic moment of light nuclei controlled cold nuclear collide fusion, belongs to the nuclear energy research and development in the field of applied technology "cold nuclear collide fusion". According to the similarity of the nuclear force constraint inertial guidance system, the different velocity and energy of the ion beam mixing control, developed ion speed dc transformer, it is cold nuclear fusion collide, issue of motivation and the nuclear power plant start-up fusion and power transfer system of the important equipment, so the merger to apply for a patent.

Please note that the patent is expected to be completely resolved once and for all mankind faces energy and environmental protection problem, so its rid progress each delayed day, all mankind will have to take more than a day of high energy costs and heavy environmental pressure. Energy industry is promoting the development of national economy of the engine, oil resources is of the great powers for the control of strategic materials. This patent invention relates to national defense security and national economic major interests. According to the patent law of the People's Republic in chapter 2, the condition of the grant of the patent right, article 25 of the patent right is granted terms, not the first paragraph (a) scientific discovery; the fifth paragraph (5) with nuclear transformation method for material. Suggest the patent of invention as a state the most confidential patent, priority support, research as soon as possible.

2 The technical background

Built by a heavy nuclear fission way to acquire nuclear energy nuclear reactor or nuclear power plant, the last century s has been successful. However, the natures of uranium resources are limited, at best only to satisfy the needs of all mankind hundreds of years. Moreover, this kind of nuclear reactor there are radioactive waste pollution post processing to the problem of landfill.

When the scientific community found the sun's energy is produced by the fusion of the later. After several generations of unremitting efforts study, at present looks like, more hope I can barely achieve short controlled nuclear fusion only the magnetic field force constraint thermonuclear fusion and inertia force

constraint thermonuclear fusion. Because the magnetic field force constraint thermonuclear fusion of the basic physical conditions, must be as high as 10^8 °C thin, above the ultra high temperature plasma, with strong magnetic field force constraint in a certain space range. Inertia force constraint thermonuclear fusion of the basic physical conditions must provide the direction of moment more strong laser energy flow, synchronous to diameter less than 1 mm pellets compression. From the nuclear overcome static electric field force barrier realize conflict fusion of the basic physical and chemical condition estimation, both need to tens of millions of degrees above the particle heat the energy of motion. So:

1. How to fusion material heated to such super high temperature?
2. How long time stably constraint live so super high temperature plasma? And try to reduce energy diffusion loss, how to realize the continuous stable and efficient conflict fusion?
3. How long can the development of high energy particles so mild high radiation (especially high efficiency after fusion of plasma temperature and ion of kinetic energy and improve several times!) it material as the boundary of the constraints and control?
4. How to smooth realization so ultra high temperature plasma continuous stable delivery and heat - electric power conversion efficiency?

Etc.....

All of these, so to speak, so harsh ultra gentle ultra-high energy condition, to the human existing science and technology level, with all the atoms or molecules consisting of all materials, are difficult to long-time stable to bear! Although now in practice, the United States, Russia, India, Japan, Korea and the European Union to the strong - strong international cooperation, in the future 30 to fifty years it is difficult to achieve lasting, reliable, stable and efficient commercial power operation.

The above three kinds of nuclear reactor nuclear reaction system, energy conversion system and safety protection system equipment is quite large, complicated and bulky, cannot be in aerospace, aviation field as an aircraft or spacecraft engine applications. More can be used as the conventional vehicle power universal use. Nuclear fusion reactor has become all mankind faces heavy energy, environmental protection pressure, the urgent need to solve, as soon as possible after sixty years still long attack means international top science problem.

The present invention project the nuclear force constraint inertial guidance cold nuclear fusion collide and ion speed dc transformer ", referred to as the "cold fusion reactor". Is completely resolved once and for all mankind faces energy and environmental protection problem, completely from another way, in the current manufacturing process technology for premise, the invention design patent.

3 Invention content

《The nuclear force constraint inertial guidance cold nuclear fusion collide and ion speed dc transformer》 of the main research content is hydrogen and deuterium and tritium, helium and lithium... And with a magnetic moment of light nuclei, in my invention, specific force constraint inertial guidance controlled cold fusion reaction cavity implementation cold nuclear collide fusion. The author in the 《modern physics classical particle quantization orbital motion model general solution of monographs, referred to as the new modern physics 》, has strict accurately to prove: the conditions within the nucleus of the nuclear force, including the so-called strong interaction force and the weak interaction force, it is in the nucleus microscopic specific conditions of formation of electric and magnetic field force interaction between the sum of the balance relationship. So, the nuclear force constraint inertial guidance cold nuclear fusion collide invention patent, is to the existing mechanical and electrical manufacturing technology level, in the macroscopic specific conditions, setting specific electromagnetic force to two series counter movement to fusion nuclear constraint in a line in the same orbit in the article); Recycle basic particle and nuclear inherent spin moment

of momentum vector formed near the speed of light spin of super rotation gyro inertial guidance characteristics, to achieve under the condition of normal temperature of collide fusion.

First of all, with a positively charged conductor plate shape, and a set of equal and fine cylindrical zone equivalent charged conductor, through specific space combination Settings, in high electric field strength and potential can be positive electrostatic field in the background, the establishment of long rectangular planar of equipotential surface. Use for fusion of light nuclei string their mutual electrostatic field repulsive force, automatic squeezed to long rectangular plane on both sides of the orbit, forming two parallel arrangement nuclear strings. So as to establish a group or an array of line cluster zero electrostatic field. (The linear area track section of the electric field strength is equal, direction vector are instead and just are cancel each other out, and electrostatic potential energy is minimum). Will be charged light nuclei with electrostatic particle linear accelerator acceleration ends after the high speed counter injection the electrostatic field force constraint formation of zero field line in orbit. Then according to stay fusion light nuclei intrinsic magnetic moment, setting additional parallel line segment of strong external magnetic field, in strong external magnetic field under the action of light nuclear magnetic dipole moment all along the line segment orbit is oriented magnetization. It can reduce the electrostatic field between adjacent nucleus repelling force, and can effectively correction gyro guidance direction. Finally, in nuclear inherent spin moment of momentum vector formed near the speed of light spin of super rotation gyro inertial guidance function, overcome the coulomb force barrier bias effect, in the same way, to realize the cold in the nuclear collide fusion. After fusion of new nuclei, such as helium nuclei, because they have no magnetic moment, but also has 2×10^7 ev more kinetic energy available, breakthrough electrostatic field force barrier and magnetic force constraints, high speed injection. The introduction of multistage ion speed dc transformer directly into voltage for $(10 \sim 1000) \times 10^3$ volt dc can output.

3.1 Force constraint inertial guidance cold nuclear fusion collide and ion speed dc transformer invention design of physical model and theoretical basis

The invention of the fundamental theory of core from the author's "modern physics classical particle quantization orbital motion model general solution" new modern physics book, in the first ~ 14 chapters system discussion of the particle, nuclear internal super spin gyro inertia directional guidance characteristics, strong, weak, electricity, magnetic interaction unity principle proof and accurate calculation method. We will first with this invention patent related physical model, the main theorem, formula and related nuclear simulation validation parameters extract is as follows:

DE Broglie early is put forward and the later confirmed that microscopic particle in volatility, its wavelength $\bar{\lambda}$, the momentum of a particle $\bar{P}=m\bar{v}$ and Planck's constant h relationship for:

$$\bar{\lambda} = \frac{h}{\bar{P}} \quad (1.1)$$

According to quantum mechanics particle wave equation and Newtonian mechanics of moment of momentum conservation law, we as long as particle characteristics of the movement to wave, spin quantization steady state vertical double track movement way simultaneous sure, static basic particle internal orbital motion characteristics is as shown in figure 1 shows, equations for:

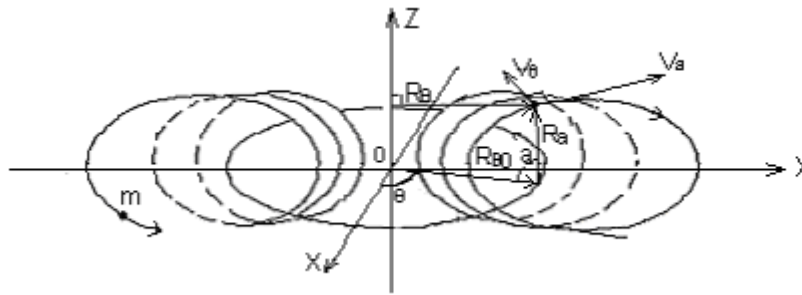

(Including: $X^2 + Y^2 = R_{\theta 0}^2$ is circle equation)

Figure 1. Static basic particle internal waves spin quantization steady state
Vertical double elliptic orbit motion diagram

$$\left\{ \begin{aligned} \vec{R}_{\alpha} \times m\vec{v}_{\alpha} &= \frac{\hbar}{2\pi} \quad \left(\frac{\hbar}{2\pi} \text{ Is moment of momentum wave vector} \right) & (1.2-1) \\ \vec{R}_{\theta} \times m\vec{v}_{\theta} &= \frac{\hbar}{2\pi} & (1.2-2) \\ \vec{R}_{\theta} &= \vec{R}_{\theta 0} - \vec{R}_{\alpha} \cos \alpha & (1.2-3) \\ \alpha &= N_{\alpha} \theta & (1.2-4) \\ \frac{\oint \vec{R}_{\theta} d\theta}{\vec{v}_{\theta}} &= \frac{N_{\alpha} \int_0^{2\pi} \vec{R}_{\alpha} d\alpha}{\vec{v}_{\alpha}} & (1.2-5) \end{aligned} \right.$$

By (1.2) equations, make $\frac{\vec{v}_{\theta}}{\vec{v}_{\alpha}} = E_{\alpha\theta} \leq 1$ for constant, you can directly derived:

$$\left\{ \begin{aligned} \vec{R}_{\alpha} &= \frac{\vec{R}_{\theta 0} E_{\alpha\theta}}{1 + E_{\alpha\theta} \cos \alpha} & (1.3-1) \\ \vec{R}_{\theta} &= \frac{\vec{R}_{\theta 0}}{1 + E_{\alpha\theta} \cos \alpha} & (1.3-2) \end{aligned} \right.$$

The results show that the basic particle fluctuation, spin of two mutually vertical motion orbits is elliptic orbit!

Along the straight line type injection of particles or nucleus, the precession direction is also spin of moment of momentum vector direction (or reverse direction). The spin precession orbital motion model in chapter 4 ~ 33 where has strict accurate proof, see figure 2:

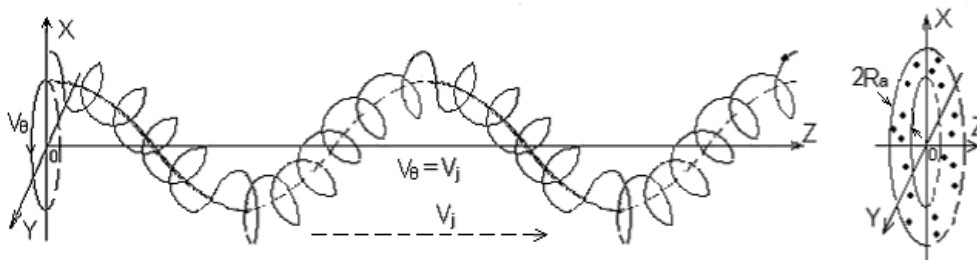

Figure 2. The basic particles along the fluctuation, spin, precession orbiting the formation of wave-particle duality characteristic diagram

Proton internal by π^+ meson and core component, the structure is shown in figure 3, each parameter simulation results are as follows:

π^+ Meson spins speed:

$$v_{\theta} = 0.6389682138 \ c$$

π^+ Meson spin movement orbit radius:

$$\begin{cases} R_{\theta 2(0)} = 0.331292 \times 10^{-15} \ m \\ R_{\theta 2(\pi)} = 1.507187 \times 10^{-15} \ m \end{cases}$$

Proton magnetic moment:

$$Up = 1.4106171 \times 10^{-26} \ J/T$$

Proton nuclear core fluctuation velocity:

$$v_{\alpha} = \beta_i c \approx c$$

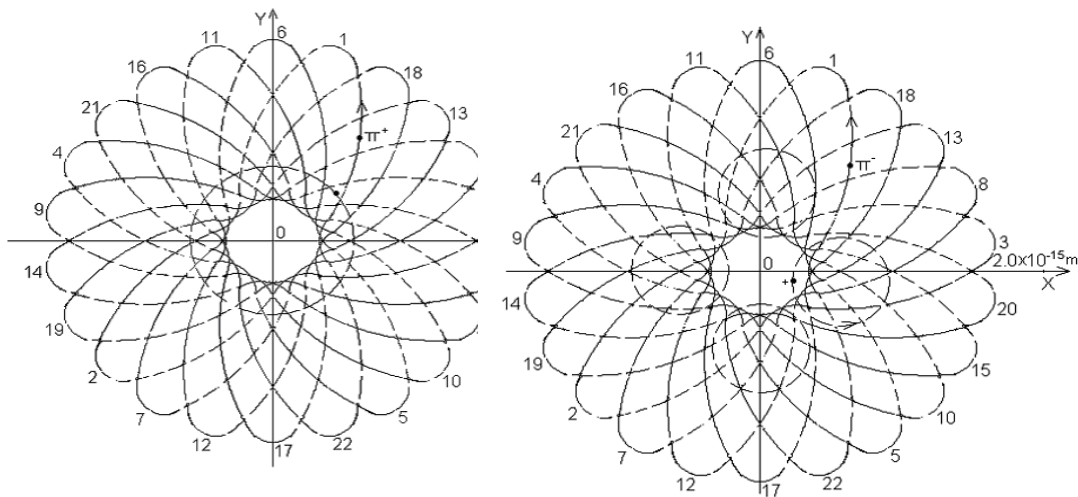

Figure 3. Protons, neutrons internal π^{\pm} meson, core fluctuations, spin motion orbit
In XOY plane projection drawing

Among them, the neutron the internal and positively charged core component, the structure is shown in figure 3, each parameter simulation results are as follows:

π^- Meson spins speed:

$$v_{\theta} = 0.6389682138 \ c$$

π^- Meson spin movement orbit radius:

$$\begin{cases} R_{\theta 2(0)} = 0.415254 \times 10^{-15} \ m \\ R_{\theta 2(\pi)} = 1.889164 \times 10^{-15} \ m \end{cases}$$

Neutron magnetic moment:

$$Un = -0.9661136 \times 10^{-26} \ J/T$$

Neutron nuclear core fluctuation velocity:

$$v_{\alpha} = \beta_i c \approx c$$

Because the deuterium nuclei (hereinafter referred to as D nuclear, similarly hereinafter). The protons and neutrons composition, magnetic moment is: $Ud = 0.4330574 \times 10^{-26} \ J/T$, about equal to the protons and neutrons of magnetic moment difference $\Delta U = 0.4445035 \times 10^{-26} \ J/T$. Tritium nuclei of protons

and two neutrons to composition, magnetic moment is: $Ut = 1.504553 \times 10^{-26} \text{ J/T}$, and proton magnetic moment almost equal. From their magnetic moment value can judge: deuterium nuclei by proton neutron along the spin axis cascading into; Tritium the conditions within the nucleus proton is located in the middle, on both sides of the symmetrical distribution of neutron magnetic moment spin in opposite directions, just offset, see figure 4.

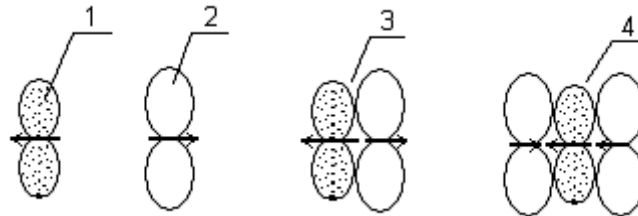

Figure 4. Protons, neutrons, deuterium and tritium nuclei of the internal be component and magnetic moment synthetic principle diagram 1. The proton and spin magnetic moment vector 2. Neutron and spin magnetic moment vector 3. Deuterium nuclei of internal are component and magnetic moment synthetic principle 4. Tritium nuclei of internal structure and magnetic moment synthetic principle

According to the definition of electrodynamics of magnetic moment, by (1.3) equations, nuclear magnetic moment is charged by the basic particles along the closed orbital motion form, deuterium nuclear magnetic moment obviously is mainly composed of protons and neutrons with unit in charge of all the elementary particle spin motion comprehensive formation. The equivalent current I_0 and Circular ring current radius \bar{r}_0 respectively is:

$$U_d = \pi \bar{r}_0^2 I_0 = \pi \bar{r}_0^2 \frac{ev_\theta}{2\pi \bar{r}_0} = \frac{ev_\theta \bar{r}_0}{2} \tag{1.4}$$

Will the U_d 、 v_θ value into the (1.4) type, to: $\bar{r}_0 = 2.82205 \times 10^{-16} \text{ m}$, $I_0 = 17308.75 \text{ A}$.

3.2 Conflict fusion D nuclear string and ion speed dc transformer current density estimation

3.2.1. Conflict fusion D nuclear string density estimation

Assume that each D nuclear conflict fusion release energy efficient for 10^7 ev , 100 kw power of nuclear fusion reactor per second need D nuclear number N_d/s for:

$$N_d = \frac{10^5}{e \times 10^7} = 6.24 \times 10^{16} / s$$

Equivalent to D nuclear beam of total current intensity is 0.01 A. it is collided each D nuclear string for $3.12 \times 10^{16} / s$.

Assume that the two D nuclear list of electrostatic accelerator start for $6.5 \times 10^5 \text{ ev}$ energy, minus the reactor conflict fusion area orientation constraint original potential can 100000 ev. So, residual kinetic energy should be $5.5 \times 10^5 \text{ ev}$. The D nuclear string velocity should be:

$$v_{d1} = \sqrt{2e \times 5.5 \times 10^5 / m_d} = 7.259 \times 10^6 \text{ (m/s)} = 0.02421$$

Every D nuclear string line density δ_e and nuclear spacing ΔL respectively is:

$$\delta_e = \frac{3.12 \times 10^6}{v_{d1}} = 4.2981 \times 10^9 \text{ (}\uparrow\text{/m)}, \quad \Delta L = 1/\delta_e = 2.3266 \times 10^{-10} \text{ (m/}\uparrow\text{)}$$

Each D nuclear between potential can W_e : $W_e = \frac{e}{4\pi\epsilon_0\Delta L} = 6.1891 \text{ (ev)}$.

Set D nuclear string line density $\delta_e = 4.2981 \times 10^9 \text{ (}\uparrow\text{/m)}$, $\Delta L = R_0$, $\ln \frac{R}{R_0} = 2$, each D nuclear

beam lateral cylindrical surface radius for R in the electric field intensity, the potential can separately for:

$$E_e = \frac{e\delta_e}{2\pi\epsilon_0\Delta L} = 5.3203 \times 10^{10} \text{ (V/m)}, \quad V_e = \frac{e\delta_e}{2\pi\epsilon_0} \ln \frac{R}{R_0} = 24.7565 \text{ (V)}$$

The ΔL spacing value and the estimation results, in this ΔL spacing, D nuclear string density increased 10 ~ 100 times is feasible, which can be used to estimate the single beam conflict fusion power has (0.1 ~ 10) Mw (million watts) adjustable change interval.

If the above two single beam string D nuclear force constraint inertial guidance conflict cold fusion experimental can succeed, we can consider to use multiple parallel arrangement, then the multiple parallel arrangement for group, the combination use of a set of electrostatic accelerator and ion speed dc transformer and other ancillary equipment. In order to make cold nuclear fusion collide with the total power of the geometric series expansion.

3.2.2. Ion speed dc transformer current intensity estimation

Similarly, if the output power of 100 kw, the voltage is 1000 V dc can, the current strength for 100 A. Suppose this 100A current by cold fusion is a particle by multiple ion speed dc transformer continuous decompression after forming, for a particle with two units of positive charge in the final stage decompression, a particle movement speed for:

$$v_\alpha = \sqrt{4e \times 1000 / m_\alpha} = 3.105198 \times 10^5 \text{ (m/s)} = 0.00103$$

Every a particle string line density δ_e and particle spacing ΔL respectively is:

$$\delta_e = \frac{100(A)}{2ev_\alpha} = 1.005 \times 10^{15} \text{ (}\uparrow\text{/m)}, \quad \Delta L = 1/\delta_e = 9.95 \times 10^{-16} \text{ (m/}\uparrow\text{)}$$

The estimation of a particle string particle spacing ΔL than nuclear spacing is small! Obviously, it is not possible. Fortunately ion speed dc transformer within the constraints of electromagnetic field strength requirement is not high, and the nuclear fusion does not exist along the vertical direction injection problem. We can be in more than 10000V dc transformer with high pressure of blood pressure, design intensive honeycomb composite structure, the cluster number directly increase tens of thousands of times! (See behind

argument). Low pressure parts adopt conventional means decompression. Or directly r&d high voltage high speed high-power dc motor.

3.3 Third linear zero electric field design principle

3.3.1 Electrostatic field force to fusion light nuclei constraint capacity estimation

If there are two infinite uniform charged thin cylindrical conductor, show as shown in figure 5 shows parallel distribution. Intermediate have two deuterium light nuclei head on conflict or behind collision, but due to the coulomb barrier repulsive force function can lead to deviation "rub shoulders" and. A thin cylindrical charge line density of δ_{ced} , the coulomb's law and gauss theorem, thin cylindrical conductor of the

electrostatic field strength E_e for:

$$E_e = \frac{\delta_{ced}}{2\pi\epsilon_0 R_x} \tag{1.5}$$

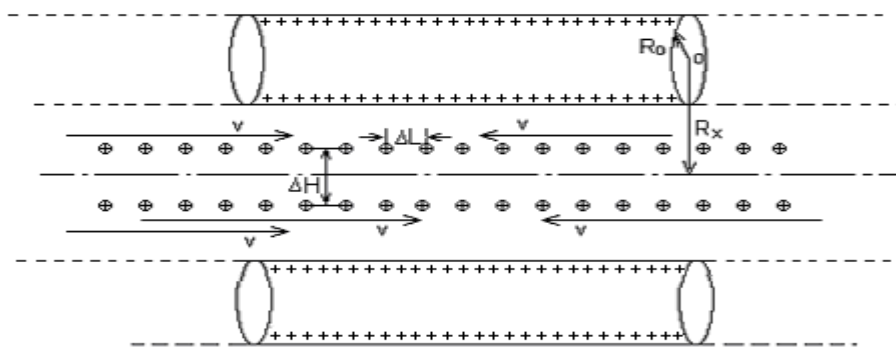

Figure 5. Electrostatic field force constraint light nuclear capacity estimation principle diagram

"Rub shoulders" and the two light nuclei in two thin cylindrical conductor electrostatic field forces under the action of the extrusion, equilibrium condition is:

$$\frac{e\delta_{ced}}{2\pi\epsilon_0(R_x - 0.5\Delta H)} = \frac{e\delta_{ced}}{2\pi\epsilon_0(R_x + 0.5\Delta H)} + \frac{e^2}{2\pi\epsilon_0\Delta L\Delta H} \tag{1.6}$$

When $R_x \gg \Delta H \rightarrow \Delta L$, make $\Delta H \rightarrow 2\bar{r}_0$ (make D nuclear diameter $2\bar{r}_0 = 2 \times 10^{-15} m$), the (1.6) type, to:

$$\delta_{ced} = \frac{eR_x^2}{\Delta L\Delta H^2} = \frac{eR_x^2}{8r_0^3} \tag{1.7}$$

Hypothesis of $R_x = 0.1 m$, into the type: $\delta_{ced} = 2.00272 \times 10^{23} (C/m)$. If the thin cylindrical conductor radius $R_0 = 0.05 m$, the fine cylinder surface potential V must be more than:

$$V = \int_{R_0}^{R_x} \frac{\delta_{ced}}{2\pi\epsilon_0 R_x} dR_x = \frac{\delta_{ced}}{2\pi\epsilon_0} \ln \frac{R_x}{R_0} = 2.49527 \times 10^{33} (V) \tag{1.8}$$

From the above simple estimation results show that: it is almost astronomical levels of voltage value! Description in a simple parallel uniform charged fine straight cylindrical conductor combination form of pure

electrostatic field, to realize the light nuclei and effective to overcome Coulomb electrostatic field strong base head or car tracing caudal conflict fusion, the electric field and potential strength are to high, we simply cannot rely on the existing mechanical and electrical equipment manufacturing technology level to charge produce such high voltage!

If the chart 5 D nuclear string directly from their own inner field into two beam, a $R_x > \Delta H \gg \Delta L$, is still the (1.6) type:

$$\delta_{ecd} = \frac{eR_x^2}{\Delta L \Delta H^2} \tag{1.9}$$

Make $\Delta H = 10^{-2} m$, $\Delta L = 10^{-10} m$, into the type: $\delta_{ecd} = 1.6022 \times 10^{-7} (C/m)$, $V = 1996V$.

The voltage value is the existing mechanical and electrical equipment manufacturing technology level is very easy to charge do. This is to make full use of D nuclear series of electric field in the physical model and theoretical basis.

3.3.2 Flat shape positively charged conductor and a group of fine cylindrical positively charged conductor of the linear zero field forming principle

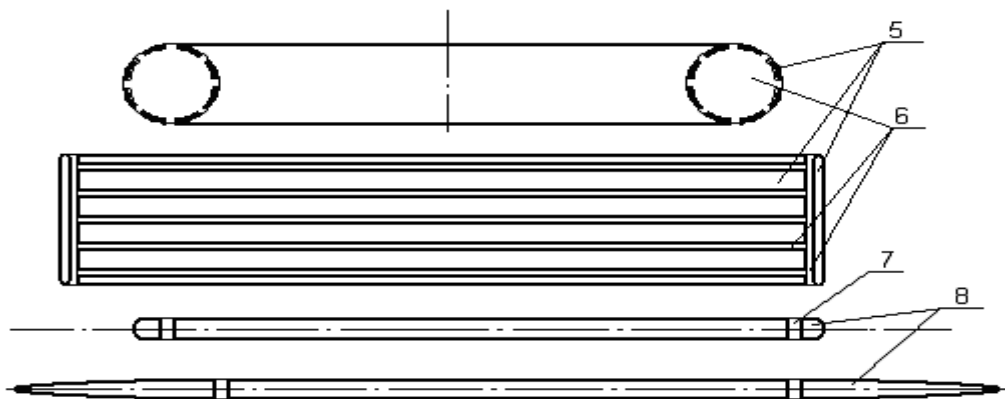

Figure 6. Round ring, plate shape and fine cylindrical conductor surface charge density of the original surface is roughly equivalent to the forming principle of figure 5. Round ring peace tabular conductor each conductor round ring peace tabular points conductor separation between dielectric 7. Fine cylindrical conductor on both sides of the space dielectric 8. Fine cylindrical conductor on both ends of the point's conductor

The physical characteristics of the electrostatic field, it is known that in static equilibrium, the charge is distributed in the conductor surface, power lines are perpendicular to the conductor surface, and conductor surface is an equipotent body. In order to realize the design of this invention patent required linear zero field, must first achieve certain size round ring, plate shape and limited length of thin cylindrical conductor in the electrostatic field interaction, the conductor surface electrostatic charge of the original and density distribution, or nearly the same density distribution. For this reason, the circular ring conductor, may give a conductor surface along the parallel circle line is divided into $6 \sim N$ circle piece. (N values no upper limit, can realize the conductor surface of the original charge surface density is equal to prevail). Ring piece electricity medium between separate component conductors. The flat shape conductor, the percentage of separating a long strip points conductor, edge with slender half cylindrical points around the conductor, between power medium separated. Similarly, the limited long thin cylindrical conductor can be in both ends additional a pair of half globular or half of globular points conductor, see figure 6. When necessary, return can again section or

along the axis incision in 2 ~ N points between conductors, also they use electricity from medium. So, as long as according to each conductor in electric fields of the electric field interaction, to calculate the additional voltage, and then to each conductor points respectively in different conductor charge voltage value, we can achieve each conductor surface of the original charge surface density or line density roughly equal.

According to the electrostatic field characteristics, two equal parallel distribution of infinite thin cylindrical conductor, when they are equal with positive charge, in cross section, the power distribution is shown as shown in figure 7.

In the middle of ABC symmetry plane, make fine cylindrical conductor charge line density of δ_{ce} , the gauss theorem, and the electric field strength E_A for:

$$E_A = \frac{\delta_{ce}}{2\pi\epsilon_0 R_0} \cdot 2 \sin \alpha = \frac{\delta_{ce} \sin 2\alpha}{2\pi\epsilon_0 R_0} \tag{1.10}$$

Along the ABC symmetry plane, when $\alpha=0^\circ$, in B, electric field strength to zero, but potential can be maximum. With the charge was to A, C direction rejection. When $\alpha=45^\circ$, $E_A = \frac{\delta_{ce}}{2\pi\epsilon_0 R_0}$ is A maximum, as shown in figure 7, A point (please note: "⊕" is linear zero field A cross section of A symbol, the same below). When we will plate shape positively charged conductor and shown in figure 7 fine cylindrical positively charged conductor in figure 8, as shown in the set space, as long as the plate shape charged conductor side uniform electric field strength E_{ep} is slightly less than (1.10) type A maximum of

$E_A = \frac{\delta_{ce}}{2\pi\epsilon_0 R_0}$, the figure 8 A point can be formed near two linear zero field.

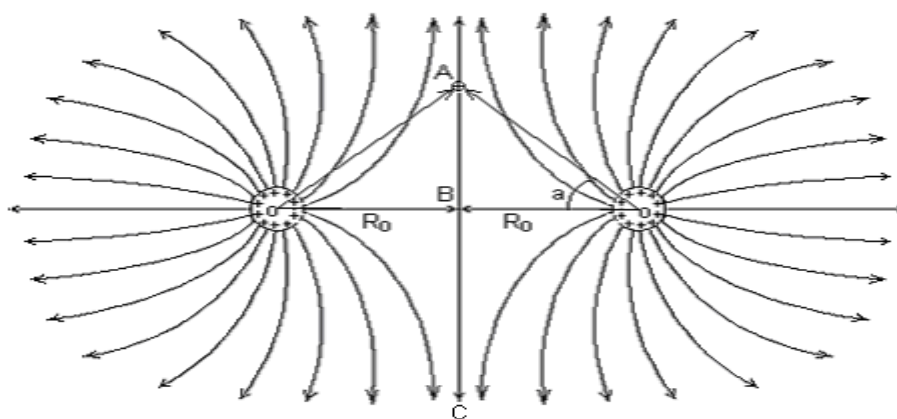

Figure 7. Two parallel set infinite thin cylindrical zone equivalent charged conductor power distribution diagrams

In the figure 8 shows the linear zero field forming principle diagram, make flat shape conductor surface density of charge of the δ_{ep} , and for the dielectric distance for $d = 0.20$ m, thin cylindrical conductor charge

line density of δ_{ex} , along the linear zero field arranged d nuclear string charge line density of δ_{ed1} and δ_{ed2} , spacing for ΔH , $\alpha_0 = 45^\circ$. The electrostatic field force in the symmetry plane two beam D nuclear series integrated the interaction of electrostatic field force balance principle, we have:

$$\left\{ \begin{aligned} \frac{e\delta_{ex}}{2\pi\epsilon_0} \cdot \frac{2\sin\alpha_1 \cos\alpha_1}{R_{ex}} &= \frac{e\delta_{ed2}}{2\pi\epsilon_0\Delta H} + \frac{e\delta_{ep}}{\epsilon_0} & (1.11-1) \\ \frac{e\delta_{ex}}{2\pi\epsilon_0} \cdot \frac{2\sin\alpha_2 \cos\alpha_2}{R_{ex}} + \frac{e\delta_{ed1}}{2\pi\epsilon_0\Delta H} &= \frac{e\delta_{ep}}{\epsilon_0} & (1.11-2) \end{aligned} \right.$$

(1.11) equations can be simplified as:

$$\left\{ \begin{aligned} \frac{\delta_{ex}}{R_{ex}} \sin 2\alpha_1 - 2\pi\delta_{ep} &= \frac{\delta_{ed2}}{\Delta H} & (1.12-1) \\ \frac{\delta_{ex}}{R_{ex}} \sin 2\alpha_2 - 2\pi\delta_{ep} &= -\frac{\delta_{ed1}}{\Delta H} & (1.12-2) \end{aligned} \right.$$

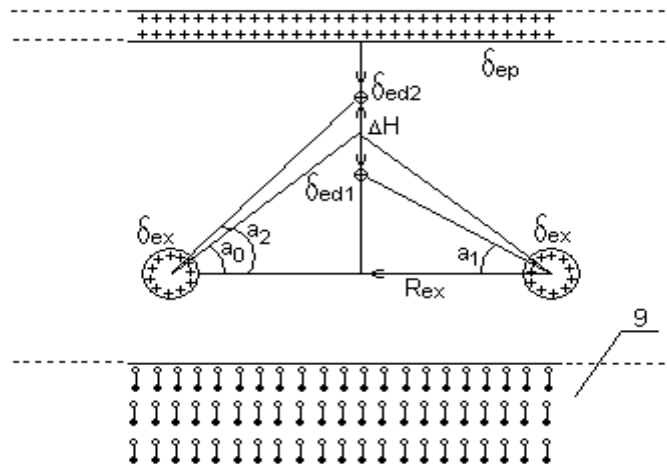

Figure 8. Flat shape positively charged conductor and 2 thin cylindrical positively charged conductors of the linear zero fields forming principle diagram 9. And plate shape charged conductor corresponding dielectric

Make flat conductor and the dielectric composed of capacitor voltage is 40000 V, the flat conductor surface density of charge of the δ_{ep} for:

$$\delta_{ep} = \epsilon_0 E_{ep} = \epsilon_0 \frac{U_{ep}}{d} = 1.7708 \times 10^{-6} \left(\frac{C}{m^2} \right) \quad (1.13)$$

Make $\delta_{ex} = 6 \times 10^{-7} (C/m)$, $R_{ex} = 0.04m$, $\sin 2\alpha_1 = \sin(180^\circ - 2\alpha_1) = \sin 2\alpha_2$, the $\delta_{ed1} = \delta_{ed2}$, (1.12) further simplified equations for:

$$\delta_{ex} \cdot \frac{\sin 2\alpha_1}{R_{ex}} = 2\pi\delta_{ep} \quad (1.14)$$

By (1.12) equations, we can calculate the δ_{ep} invariable situation, thin cylindrical conductor charge line density δ_{ex} small range change on D nuclear string density δ_{ed1} and spacing ΔH influence see table 1:

From table 1 simulation results can be seen, as long as we adjust fine cylindrical conductor or flat shape conductor inside each conductor charging voltage value, can greatly adjustment for fusion of D nuclear string density and the electric field, adjust its original charge line density δ_{ex} and can easily achieve a wide range of adjustment cold nuclear fusion collide the power! We also can adjust injection D nuclear series flow, so as to achieve the purpose of large adjustment reactor power. Also can be directly through the pre-installed in the fusion helium nuclei jet on both sides of the voltage sensor, direct and D nuclear string beam in linear zero electric field to the entrance of the shunt control electrode is linked together, make the two linear zero electric field 4 series D nuclear beam conflict fusion can be carried out smoothly, and not flow separately.

Fine cylindrical conductor charge line density δ_{ex} small range change on D nuclear string density δ_{ed1} and spacing ΔH influence table 1

| | | | | | |
|-------------------------------------|--|--------------------------|-------------------------|-------------------------|-------------------------|
| α_1 value of | 32.5 | 35 | 37.5 | 40 | 42.5 |
| α_2 the calculated value of | 57.5 | 55 | 52.5 | 50 | 47.5 |
| ΔH the calculated value m | 0.03730 | 0.02912 | 0.02144 | 0.01411 | 0.006999 |
| $\delta_{ex} = C/m$ | D nuclear string density δ_{ed1} simulation value (C/m) | | | | |
| $\delta_{ex} = 4.65 \times 10^{-7}$ | -2.2023×10^{-8} | -5.8921×10^{-9} | 2.2002×10^{-9} | 4.5452×10^{-9} | 3.1810×10^{-9} |
| $\delta_{ex} = 6 \times 10^{-7}$ | 9.2070×10^{-8} | 8.6461×10^{-8} | 7.2095×10^{-8} | 5.1443×10^{-8} | 2.6713×10^{-8} |
| $\delta_{ex} = 10^{-6}$ | 4.3012×10^{-7} | 3.6010×10^{-7} | 2.7919×10^{-7} | 1.9040×10^{-7} | 9.6436×10^{-8} |
| $\delta_{ex} = 1.5 \times 10^{-6}$ | 8.5269×10^{-7} | 7.0215×10^{-7} | 5.3806×10^{-7} | 3.6409×10^{-7} | 1.8359×10^{-7} |

Among them, if $\delta_{ex} = 4.65 \times 10^{-7} \rightarrow 1.5 \times 10^{-6} (C/m)$, $\ln \frac{R_{ex}}{R_0} = \ln 3$, the thin cylindrical conductor of the original charge voltage value $U_{ex} = \frac{\delta_{ex}}{2\pi\epsilon_0} \ln 3 = 9182 \rightarrow 29621 (V)$, also in the existing mechanical and electrical manufacturing technology level within the scope of the license. Data in table 1 to δ_{ed1} value take 2.2002×10^{-9} and 8.5269×10^{-7} two extreme, into the $\Delta L = \frac{e}{\delta_{ed1}}$ type, to: ΔL

were 7.2820×10^{-11} m, 1.8790×10^{-13} m, are also in the ideal range.

Similarly, four thin cylindrical positively charged conductor, and flat shape charged conductor combination power can synthesis we need three groups were among six linear zero field, see figure 9. When necessary, we can in flat charged conductor on both sides of the arrangement of a set of fine cylindrical charged conductor, linear zero field of double beam number again.

Please note: in the practical design scheme, fusion cavity particle perpendicular to the D nuclear series injection position and the nearby, thin cylindrical, flat shape charged conductor and the strengthening of the magnetic field direction of magnetization should be slightly upward projection bending; Flat shape charged conductor here opened a long and narrow gap, make the particle can only along the single direction injection, so it is easy to will particle energy concentrated into a multistage continuous ion speed in dc step-down transformer.

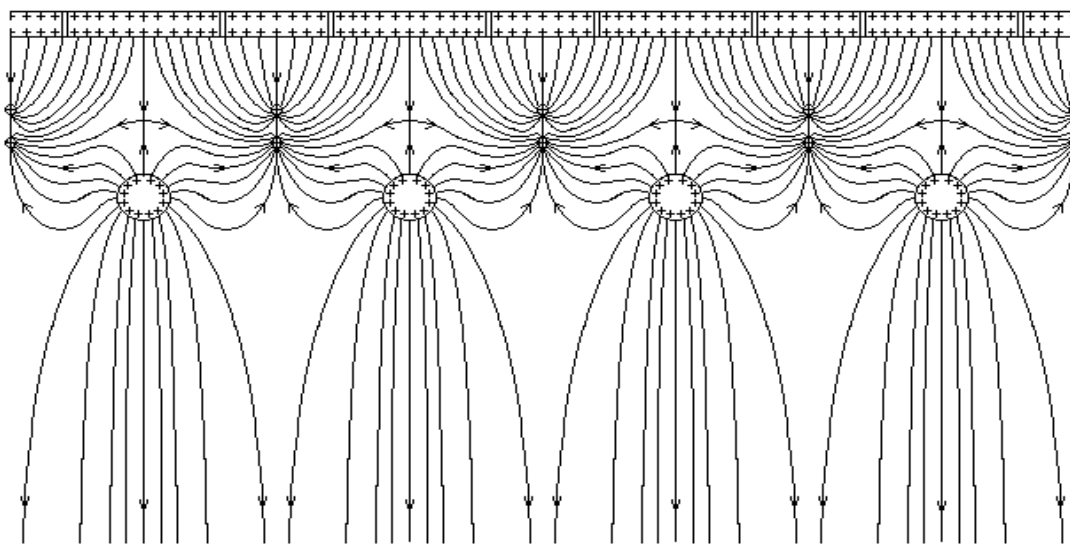

Figure 9. Flat shape positively charged conductor and a group of fine cylindrical positively charged conductor combination of power and the formation of linear zero field principle diagram

3.3.3 A group of circular ring charged conductor and a few thin cylindrical charged conductor combination of linear zero fields forming principle

3.3.3.1 In circular ring conductor axis inside electric field strength and potential can change characteristics

Hypothesis conductor ring charge on line density δ_{he} : $\delta_{he} = \frac{Q}{2\pi R_{he}}$ $dQ = \delta_{he} dl = \frac{Q}{2\pi} d\beta$, see

figure 10.

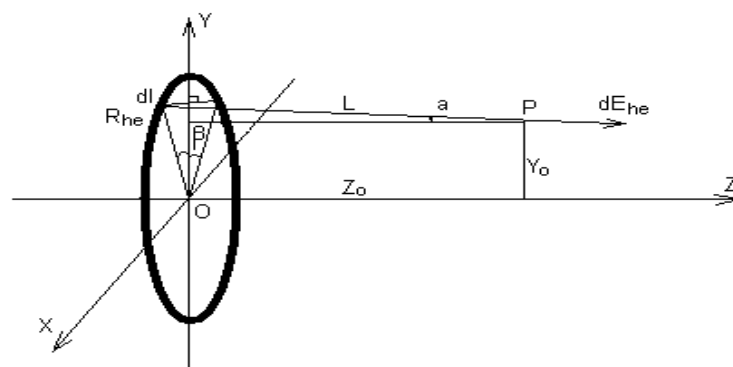

Figure 10. Circular conductor ring inside of the electric field strength E_{hz} , E_{hy}

change calculation principle diagram

We will be the first to OYZ plane symmetry can be divided into two and a half ring, make full use of Gaussian symmetry principle, the:

$$L = \sqrt{(R_{he} \sin\beta)^2 + (R_{he} \cos\beta - Y_0)^2 + Z_0^2}$$

Make $Y_0/R_{he} = K_y$, $Z_0/R_{he} = K_z$, into above type to:

$$L = \sqrt{R_{he}^2 - 2R_{he}Y_0\cos\beta + Y_0^2 + Z_0^2}$$

$$= R_{he} \sqrt{1 - 2K_y \cos\beta + K_y^2 + K_z^2}$$

Make: $E_z/E_{he} = \cos\alpha$, $\cos\alpha = Z_0/L = \frac{K_z}{\sqrt{1 - 2K_y \cos\beta + K_y^2 + K_z^2}}$,

$E_y/E_{he} = \cos\theta$, $\cos\theta = \frac{R_{he} \cos\beta - Y_0}{L} = \frac{\cos\beta - K_y}{\sqrt{1 - 2K_y \cos\beta + K_y^2 + K_z^2}}$,

$$dE_{hy} = \frac{dQ}{4\pi\epsilon_0 L^2} \cos\theta$$

$$= \frac{Q}{4\pi\epsilon_0 R_{he}^2} \cdot \frac{\cos\beta - K_y}{2\pi(1 - 2K_y \cos\beta + K_y^2 + K_z^2)^{1.5}} d\beta$$

$$E_{hy} = \frac{Q}{4\pi\epsilon_0 R_{he}^2} \int_0^\pi \frac{\cos\beta - K_y}{\pi(1 - 2K_y \cos\beta + K_y^2 + K_z^2)^{1.5}} d\beta \tag{1.15}$$

By the same token:

$$E_{hz} = \frac{Q}{4\pi\epsilon_0 R_{he}^2} \int_0^\pi \frac{K_z}{\pi(1 - 2K_y \cos\beta + K_y^2 + K_z^2)^{1.5}} d\beta \tag{1.16}$$

Similarly, potential can be expressed as:

$$V_{hz} = \frac{Q}{4\pi\epsilon_0 R_{he}} \int_0^\pi \frac{1}{\pi(1 - 2K_y \cos\beta + K_y^2 + K_z^2)^{0.5}} d\beta \tag{1.17}$$

E_{hy} Integral coefficient $\int_0^\pi \frac{\cos\beta - K_y}{\pi(1 - 2K_y \cos\beta + K_y^2 + K_z^2)^{1.5}} d\beta$ calculation results table 2

| K _z | K _y | | | | | | | | | |
|----------------|----------------|---------|---------|---------|---------|---------|---------|---------|---------|---------|
| | 0.01 | 0.1 | 0.2 | 0.3 | 0.4 | 0.5 | 0.6 | 0.7 | 0.8 | 0.9 |
| 0 | -0.005 | -0.0506 | -0.1047 | -0.1668 | -0.2432 | -0.3449 | -0.4934 | -0.7389 | -1.234 | -2.7490 |
| 0.1 | -0.0048 | -0.0483 | -0.0997 | -0.1579 | -0.2282 | -0.3186 | -0.4430 | -0.6261 | -0.9020 | -1.1352 |
| 0.2 | -0.0042 | -0.0420 | -0.0860 | -0.1342 | -0.1888 | -0.2522 | -0.3250 | -0.3977 | -0.4200 | -0.2139 |

| | | | | | | | | | | |
|-----|----------------|----------------|----------------|----------------|----------------|----------------|----------------|----------------|----------------|--------|
| 0.3 | -0.0033 | -0.0332 | -0.0670 | -0.1018 | -0.1375 | -0.1717 | -0.1977 | -0.1976 | -0.1319 | 0.0559 |
| 0.4 | -0.0023 | -0.0234 | -0.0463 | -0.0680 | -0.0864 | -0.0979 | -0.0950 | -0.0646 | 0.0110 | 0.1429 |
| 0.5 | -0.0014 | -0.0141 | -0.0272 | -0.0376 | -0.0431 | -0.0402 | -0.0233 | 0.0144 | 0.0791 | 0.1698 |
| 0.6 | -0.0006 | -0.0063 | -0.0112 | -0.0131 | -0.0101 | 0.00075 | 0.0226 | 0.0585 | 0.1099 | 0.1735 |
| 0.7 | -0.0000 | -0.0002 | -0.0010 | 0.0049 | 0.0132 | 0.0276 | 0.0499 | 0.0814 | 0.1215 | 0.1675 |
| 0.8 | 0.00041 | 0.0042 | 0.0096 | 0.0172 | 0.0283 | 0.0439 | 0.0649 | 0.0916 | 0.1231 | 0.1574 |
| 0.9 | 0.0007 | 0.0072 | 0.0152 | 0.0250 | 0.0373 | 0.0528 | 0.0718 | 0.0943 | 0.1194 | 0.1457 |
| 1.0 | 0.00088 | 0.0089 | 0.0185 | 0.0294 | 0.0420 | 0.0567 | 0.0737 | 0.0927 | 0.1131 | 0.1338 |

$$E_{hz} \text{ Integral coefficient } \int_0^\pi \frac{K_z}{\pi(1 - 2K_y \cos\beta + K_y^2 + K_z^2)^{1.5}} d\beta \text{ calculation results table 3}$$

| K _z | K _y | | | | | | | | | | |
|----------------|----------------|--------|--------|--------|--------|--------|--------|--------|--------|--------|--------|
| | 0.0 | 0.01 | 0.1 | 0.2 | 0.3 | 0.4 | 0.5 | 0.6 | 0.7 | 0.8 | 0.9 |
| 0.1 | 0.0985 | 0.0985 | 0.1007 | 0.1077 | 0.1209 | 0.1435 | 0.1819 | 0.2513 | 0.3906 | 0.7225 | 1.6891 |
| 0.2 | 0.1886 | 0.1886 | 0.1924 | 0.2047 | 0.2275 | 0.2653 | 0.3267 | 0.4285 | 0.6036 | 0.9084 | 1.3607 |
| 0.3 | 0.2636 | 0.2637 | 0.2684 | 0.2832 | 0.3102 | 0.3532 | 0.4186 | 0.5163 | 0.6579 | 0.8449 | 1.0293 |
| 0.4 | 0.3202 | 0.3202 | 0.3250 | 0.3399 | 0.3662 | 0.4063 | 0.4632 | 0.5399 | 0.6355 | 0.7381 | 0.8144 |
| 0.5 | 0.3578 | 0.3578 | 0.3621 | 0.3752 | 0.3979 | 0.4308 | 0.4745 | 0.5282 | 0.5872 | 0.6408 | 0.6710 |
| 0.6 | 0.3783 | 0.3783 | 0.3818 | 0.3924 | 0.4100 | 0.4346 | 0.4654 | 0.5001 | 0.5343 | 0.5605 | 0.5695 |
| 0.7 | 0.3849 | 0.3849 | 0.3875 | 0.3953 | 0.4080 | 0.4250 | 0.4451 | 0.4661 | 0.4843 | 0.4952 | 0.4940 |
| 0.8 | 0.3809 | 0.3809 | 0.3827 | 0.3881 | 0.3966 | 0.4075 | 0.4196 | 0.4310 | 0.4393 | 0.4416 | 0.4354 |
| 0.9 | 0.3696 | 0.3696 | 0.3708 | 0.3741 | 0.3793 | 0.3856 | 0.3920 | 0.3972 | 0.3994 | 0.3969 | 0.3884 |
| 1.0 | 0.3536 | 0.3536 | 0.3542 | 0.3561 | 0.3588 | 0.3618 | 0.3644 | 0.3656 | 0.3642 | 0.3592 | 0.3497 |

$$\text{Potential } V_{he} \text{ integral coefficient } \int_0^\pi \frac{1}{\pi(1 - 2K_y \cos\beta + K_y^2 + K_z^2)^{0.5}} d\beta \text{ calculation results table 4}$$

| K _z | K _y | | | | | | | | | | |
|----------------|----------------|--------|--------|--------|--------|--------|--------|--------|--------|--------|--------|
| | 0.0 | 0.01 | 0.1 | 0.2 | 0.3 | 0.4 | 0.5 | 0.6 | 0.7 | 0.8 | 0.9 |
| 0 | 1.0 | 1.0 | 1.0025 | 1.0102 | 1.0237 | 1.0441 | 1.0732 | 1.1146 | 1.1750 | 1.2703 | 1.4518 |
| 0.1 | 0.9950 | 0.9951 | 0.9974 | 1.0048 | 1.0176 | 1.0368 | 1.0639 | 1.1016 | 1.1544 | 1.2300 | 1.3349 |
| 0.2 | 0.9806 | 0.9806 | 0.9827 | 0.9891 | 1.0000 | 1.0161 | 1.0381 | 1.0669 | 1.1031 | 1.1449 | 1.1797 |
| 0.3 | 0.9578 | 0.9578 | 0.9595 | 0.9645 | 0.9729 | 0.9849 | 1.0004 | 1.0190 | 1.0391 | 1.0563 | 1.0613 |
| 0.4 | 0.9285 | 0.9285 | 0.9296 | 0.9331 | 0.9389 | 0.9466 | 0.9559 | 0.9657 | 0.9740 | 0.9772 | 0.9699 |
| 0.5 | 0.8944 | 0.8944 | 0.8951 | 0.8972 | 0.9005 | 0.9046 | 0.9088 | 0.9121 | 0.9128 | 0.9084 | 0.8961 |
| 0.6 | 0.8575 | 0.8575 | 0.8578 | 0.8587 | 0.8600 | 0.8612 | 0.8617 | 0.8606 | 0.8567 | 0.8484 | 0.8343 |
| 0.7 | 0.8192 | 0.8192 | 0.8192 | 0.8192 | 0.8190 | 0.8181 | 0.8161 | 0.8123 | 0.8058 | 0.7957 | 0.7813 |
| 0.8 | 0.7809 | 0.7809 | 0.7807 | 0.7800 | 0.7787 | 0.7764 | 0.7729 | 0.7675 | 0.7597 | 0.7490 | 0.7350 |
| 0.9 | 0.7433 | 0.7433 | 0.7429 | 0.7418 | 0.7398 | 0.7367 | 0.7323 | 0.7261 | 0.7178 | 0.7071 | 0.6939 |
| 1.0 | 0.7071 | 0.7071 | 0.7067 | 0.7053 | 0.7029 | 0.6994 | 0.6945 | 0.6880 | 0.6797 | 0.6694 | 0.6570 |

From the above along the Y and Z axis two direction of the electric field strength calculation results change trend can see: with the charge in the circular ring conductor axial inside a certain range, is to Z axis

direction, such as table 2 boldface data marked negative value range. In the existing gun, ion beam focus... And electronic components often use this special configuration of the electric field focusing effect. So, according to the preliminary results, we first gave a set of equal coaxial rings with equivalent charged conductor, the axial inside power distribution, as shown in figure 11 shows.

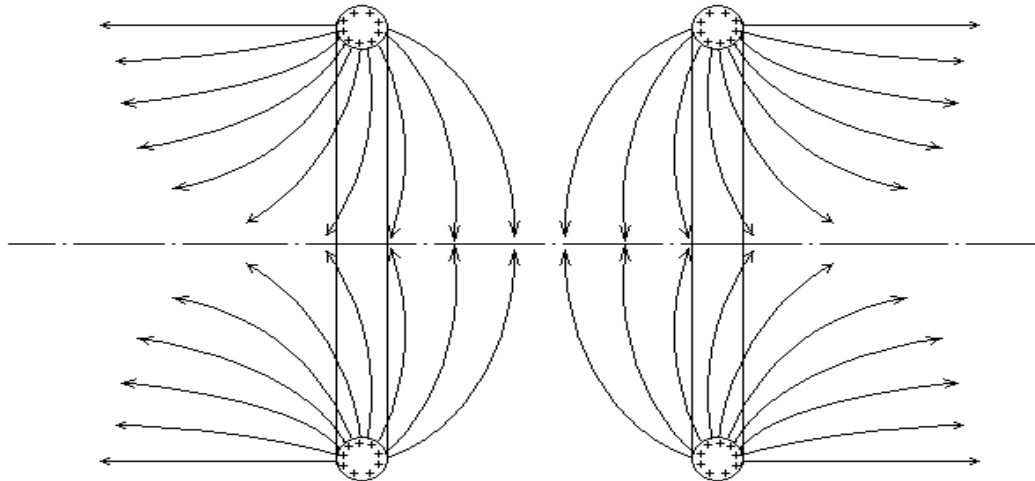

Figure 11. A group of equal coaxial rings with equivalent charged conductor axial inside power distribution diagram

3.3.3.2 A set of circular ring positively charged conductor and 2 thin cylindrical positively charged conductor combination of linear zero field forming principle

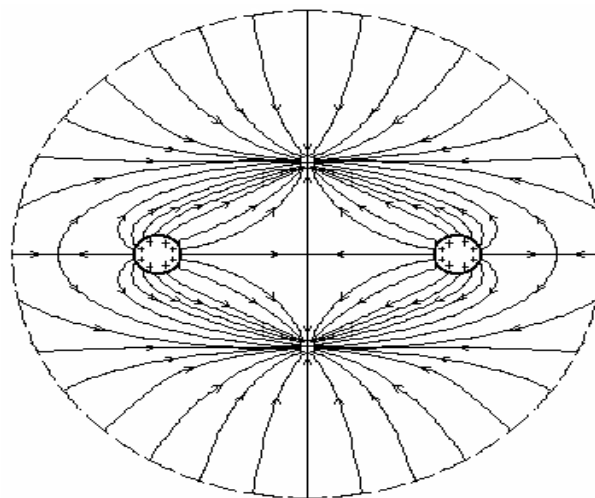

Figure 12. Two parallel infinite thin cylindrical conductors and two concentric circular ring with equivalent charged conductor in the axial cross section formed on linear zero field principle diagram

Similarly, a set of circular ring positively charged conductor and 2 thin cylindrical positively charged conductor combination of linear zero fields, in the cross section of linear zero field forming principle figure 12.

3.3.3.3 A set of circular ring positively charged conductor and 3 thin cylindrical positively charged conductor combination of linear zero fields forming principle

Set each root charged thin cylindrical conductor for the radius of R_0 , charge line density is δ_{ce} (the same below). 3 roots charged conductor parallel composition is triangular prism body, see figure 13. The

triangular prism in the cross section AA'. The symmetry plane and vertical direction of the electric field strength for:

$$E_{ce} = \frac{\delta_{ce}}{2\pi\epsilon_0} \left(\frac{2\sin\alpha\cos\alpha}{R_{ce0}} - \frac{1}{\sqrt{3}R_{ce0} - R_{ce0}\text{tg}\alpha} \right)$$

$$= \frac{\delta_{ce}}{2\pi\epsilon_0 R_{ce0}} \left(\sin 2\alpha - \frac{1}{\sqrt{3} - \text{tg}\alpha} \right)$$
(1.18)

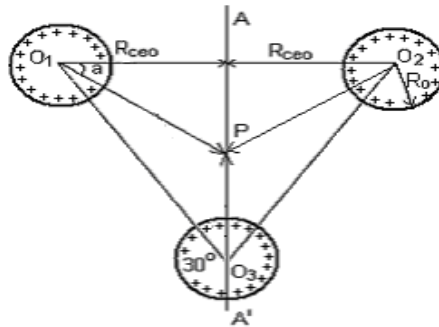

Figure 13. 3 root infinite thin cylindrical positively charged conductor triangle combination of the electric field strength calculation principle diagram

By (1.18) type, if make $\sin 2\alpha - \frac{1}{\sqrt{3} - \text{tg}\alpha} = 0$, the $\alpha = 30^\circ$. That is in the center of the triangle

point P, total electric field intensity vector and 0. The AA' The symmetry plane of the electric field strength factor (in parentheses) calculation results see table 5. Table 5 shows, with the charge, in point P is not stable, the AA' Symmetry plane, were to A direction of rejection. Through the regular triangle of Angle bisector and gauss theorem of symmetry analysis can determine: two concentric circular rings with equal number of positive charge conductor and thin cylindrical conductor is parallel regular triangle, hexagonal combination, in vertical axis cross section formed on linear zero field cluster distribution features, will be shown in figure 14.

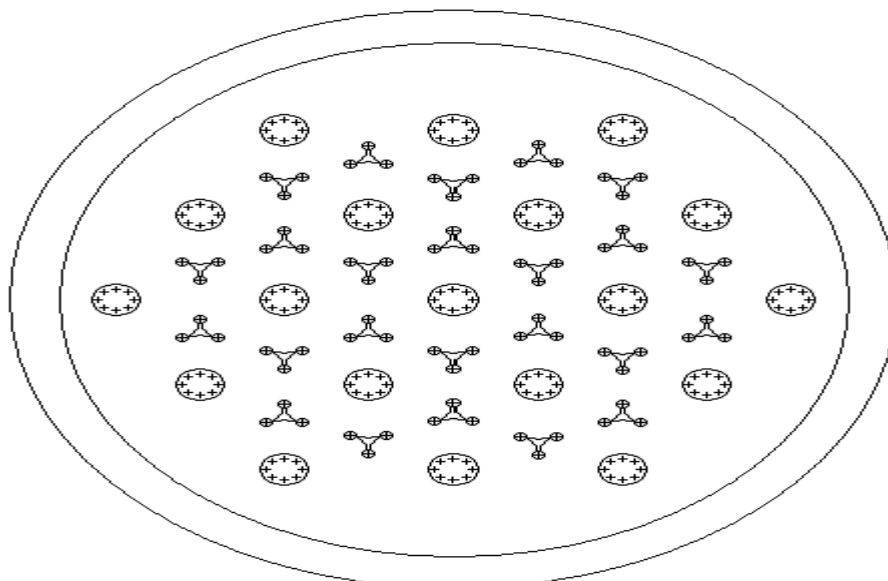

Figure 14. Two concentric circular ring with equal number of positive charge conductor and thin cylindrical conductor is parallel regular triangle, hexagonal combination in vertical axis cross section formed on linear zero field cluster distribution diagram

The AA' the symmetry plane of the electric field strength factor $\left(\sin 2\alpha - \frac{1}{\sqrt{3} - \text{tg}\alpha} \right)$ calculation results

table 5

| | | | | | | | |
|---------------------------|---------|---------|---------|---------|---------|-----------|------|
| α 值 ($^{\circ}$) | 0 | 5 | 10 | 15 | 20 | 25 | 30 |
| () 系数 | -0.5774 | -0.4344 | -0.3008 | -0.1830 | -0.0882 | -0.0240 | 0.00 |
| α 值 ($^{\circ}$) | 35 | 40 | 45 | 50 | 55 | 60 | |
| () 系数 | -0.0294 | -0.1351 | -0.3660 | -0.8660 | -2.3508 | $-\infty$ | |

Similarly, when we will four thin cylindrical zone equivalent charged conductor and two concentric circular ring with equivalent positive charge conductor 15 combinations according to drawing, in the center of the cross section of the form, the combination of linear zero field is as shown in figure 16, figure 17 shows.

When we will many fine cylindrical conductor of the same group of concentric circular ring with equal number of positive charge conductor is parallel square combination, in vertical axis cross section formed on linear zero fields appears as shown in the diagram and cluster distribution.

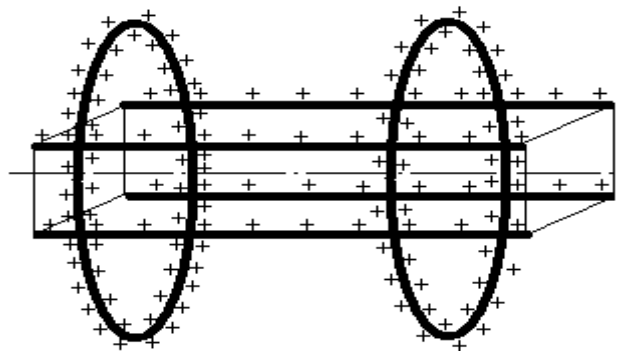

Figure 15. Uniform charged two circles, and four conductors in the combination of the electric schematic diagram

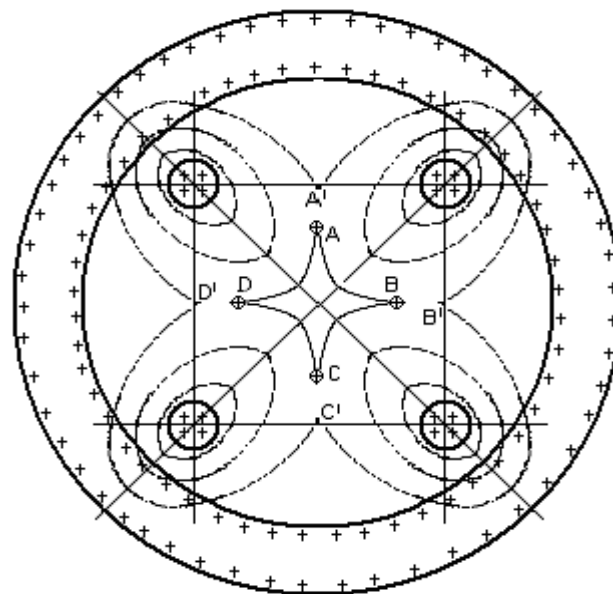

Figure 16. Combination electric field internal equipotent surface shape and the concave convex is pointed edge shape linear zero field of cross section diagram

Need to emphasize on the addition of a: figure 15, 16 and 17 shows that the combination of the electric field in the concave point four prism facets of equipotent surface, is around the extrusion is electric field force, positively charged ions can temporarily existing equipotent surface. Especially focused on AA', BB', CC', DD' four point edge line, line edges on the potential can be by a nuclear or ion high speed car tracing caudal of kinetic energy to transfer and maintain.

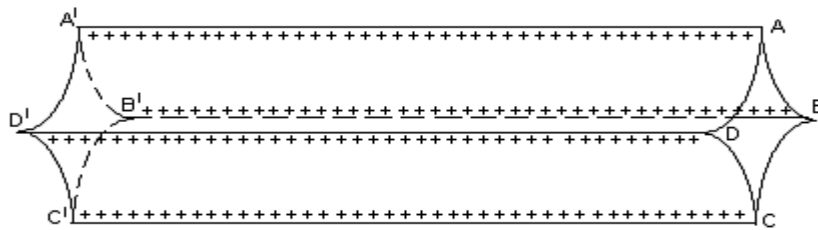

Figure 17. Combination electric field outside the concave convex point four prism facets of equipotent surface and nuclear ion from within the electric field along the ridge distribution diagram

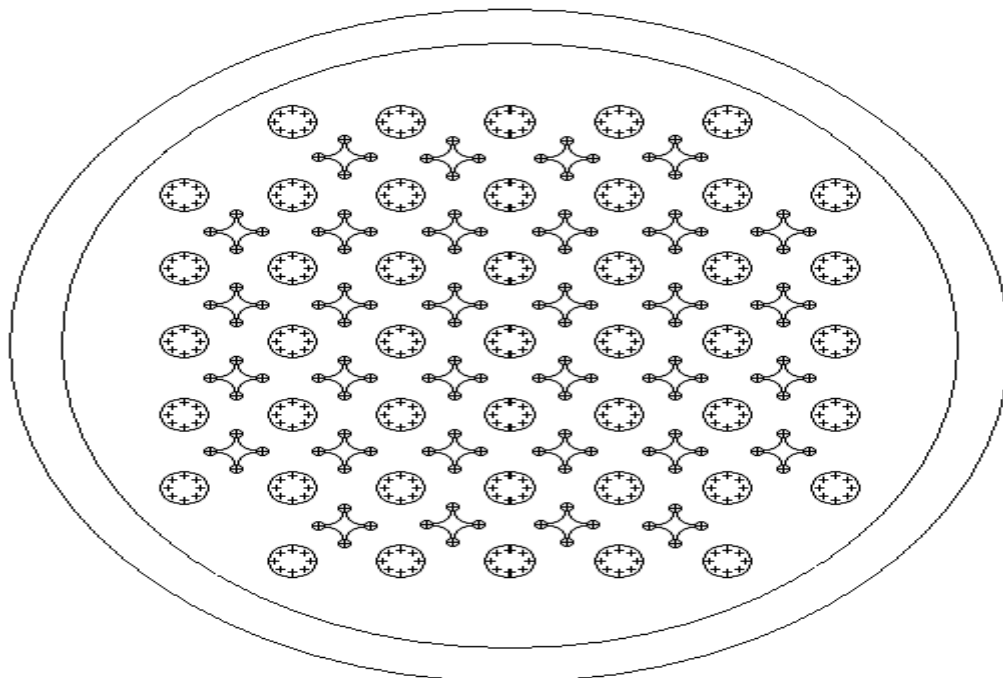

Figure a set of concentric circular ring with equal number of positive charge conductor and thin cylindrical conductor with parallel square combination in vertical axis cross section formed on linear zero fields is cluster distribution diagram

From figure 15, 16 and 17 of the uniform charged by a group of circle and four thin cylindrical conductor combination electric field internal equipotent surface shape can be seen in: as the key to the present invention, constraint ion or nuclear beam of equipotent surface concave convex outside the tip edge shape. Make the electrostatic field due to its own charge in electric field results in mutual electrostatic field repulsive force, must have been extrusion separate in the surface of the conductor is pointed in the corner. And whether electronic, ion or nucleus, are only one layer in a string, this charge layer thickness is only electronic, ion or nuclear diameter, the thickness of the entity. The surface of the conductor is still equipotent body, charge density distribution directly with the conductor surface curvature related, so AA', BB', CC', DD' four pointed

edges and the tip of the ridge line in the net with positive charge, will be along the AA', BB', CC', DD', each is a linear concentration distribution. Other recess of equipotential surface, there is no net with charge. If you applied parallel tip ridge of strong magnetic field, inevitable meeting in strong magnetic field, the magnetization by ion or nuclear own magnetic moment series up, along the four linear zero field track high concentration. At the same time, if the external magnetic field strength is enough big, conflict between nucleuses there are still quite big attractions between opposite poles. This is what we want.

3.4 Segments zero field outside strengthen field magnetization settings to fusion light nuclear directional binding effect estimation

When to fusion of light nuclei D nuclear beam, injection as shown in figure 9 shows with linear zero field cold fusion reaction cavity, as long as the adjacent light nuclei spacing far outweigh the nuclear radius r_0 , ($\Delta L \gg r_0$), electrostatic field force is very easy to be fusion light nuclei are constraint in the line segment.

In the outside world segments zero field orbit of strong magnetic field orientation magnetization, the whole lines all orbit for fusion light nuclear intrinsic magnetic moment will be shown as shown in figure 19, a directional arrangement magnetization in collusion with into a slender current solenoid. This arrangement to fusion were colliding accurate positioning guide, will obviously play a key role. The electrostatics of current solenoid magnetization formula, although each circular ring current spacing ratio nuclear magnetic moment of the equivalent radius much ($\Delta L \gg \bar{r}_0$), but through the entire D nuclear string whole slender solenoid of all Circular ring current total magnetic and not decrease, $\Phi_B = \iint \vec{B}_0 \cdot d\vec{s} = B_0 \pi \bar{r}_0^2 = B_x \pi \bar{R}_x^2$, both in circular ring current inside or outside, all is constant. Solenoid on both ends of the magnetic induction intensity B_0 for:

$$B_0 = \frac{\mu_0 n I_0}{2(n-1)\Delta L} \approx \frac{\mu_0 I_0}{2\Delta L} \tag{1.19}$$

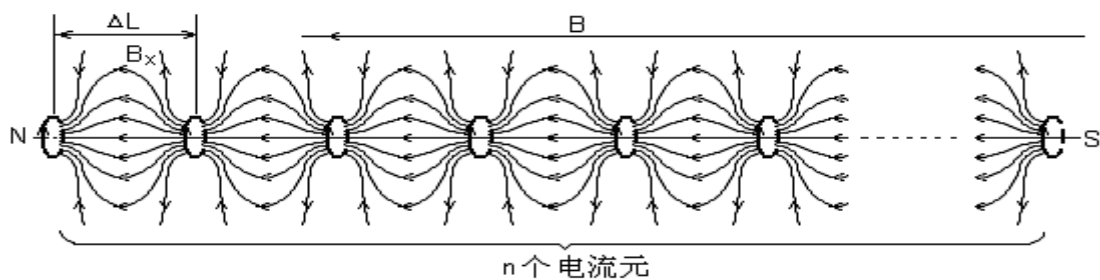

Figure 19. Along a line segment zero electric field distribution of track light nuclear magnetic moment in strong external magnetic field under the action of the magnetization is directional arrangement plan

The magnetic field of the gauss theorem, the solenoid end as shown in figure 19 shown on the left of the second c circular ring current, the circular ring current as the center, magnetic line of force is a half spherical shape to the left to the discrete, the magnetic induction intensity \vec{B}_x vector can approximate representation for:

$$\vec{B}_x = B_0 \frac{\bar{r}_0^2}{R_x^3} \vec{R}_x \tag{1.20}$$

In the line zero field consisting of the orbit intermediate, when two D nuclear spacing from $\Delta L \rightarrow \bar{r}_0$ collide head-on, as shown in figure and shown before. Make $\Delta L \gg \bar{r}_0$, charged particle fluctuation velocity for c, the Coulomb's law and (1.19) and (1.20) type, its parallel D nuclear string direction the interaction of electric and magnetic potential U_e , U_b respectively expressed as:

$$U_e = \int_{\bar{r}_0}^{\Delta L} \frac{e^2}{4\pi\epsilon_0\Delta L^2} d(\Delta L) = \frac{e^2}{4\pi\epsilon_0\bar{r}_0} \tag{1.21}$$

$$U_b = -\int_{\bar{r}_0}^{\Delta L} 2\pi \bar{r}_0 \vec{I}_0 \times \vec{B}_x \text{tg} \alpha d(\Delta L) = -\int_{\bar{r}_0}^{\Delta L} ec \frac{\mu_0 I_0}{2\Delta L} \left(\frac{\bar{r}_0}{\Delta L}\right)^3 d(\Delta L) = -\int_{\bar{r}_0}^{\Delta L} \frac{e^2 \bar{r}_0^2}{4\pi\epsilon_0\Delta L^4} d(\Delta L)$$

$$= -\frac{e^2}{12\pi\epsilon_0\bar{r}_0} \tag{1.22}$$

The above derivation calculus proof: electrostatic field repulsive force and exclusive energy far outweigh the circular ring current magnetic attraction and attract energy. The total energy should be equal to provide two D nuclear head on conflict fusion of at least kinetic energy. Because D nuclear protons and neutrons series composition, the scope of nuclear force for 10^{-15}m , it can be used as fusion instantly overcome Coulomb potential of \bar{r}_0 value. Hypothesis linear zero field starting voltage is 10^5V , the electrostatic accelerator starting potential can value U_0 for:

$$U_0 \geq \frac{U_e + U_b}{2} + 100000e \geq \frac{e^2}{12\pi\epsilon_0\bar{r}_0} + 100000e \tag{1.23}$$

3.5 D nuclear nearly the speed of light spins forming super rotation gyro inertia guidance function

Assume that a string of D nuclear along a linear zero field of straight orbital motion, in linear shaped zero electric field force and parallel strong external magnetic field force under the action of the double constraint, their nuclear spin vector will coincidence in the same line the orbit, and with strong external magnetic field parallel. For the whole series D nuclear middle arbitrary a nucleus, nucleus is on both sides of the electrostatic field force of repulsion effect, along the direction parallel to the electrostatic field interaction force equal, the direction on the contrary, cancel each other out. Due to the neutron core units with a positive charge is D nuclear net with positive charge, it is in the same nearly the speed of light wave speed of circular motion. Along with the neutron core fluctuations and additional movement, they will try and shows way collective motion, and its overall potential will can drop to the minimum. The Coulomb's law, two sides D nuclear to intermediate a D nuclear vertical D nuclear string direction of the electrostatic field force $F_{e\perp}$ for:

$$F_{e\perp} = \sum_{i=1}^n \frac{4\bar{r}_0 e^2}{4\pi\epsilon_0 \left[(2\bar{r}_0)^2 + (2n-1)^2 \Delta L^2 \right]^{\frac{3}{2}}}$$

$$= \sum_{i=1}^n \frac{e^2 \bar{r}_0}{4\sqrt{2\pi\epsilon_0} \Delta L^3 \left[\left(\frac{\bar{r}_0}{\Delta L} \right)^2 + \left(n - \frac{1}{2} \right)^2 \right]^{\frac{3}{2}}} \tag{1.24}$$

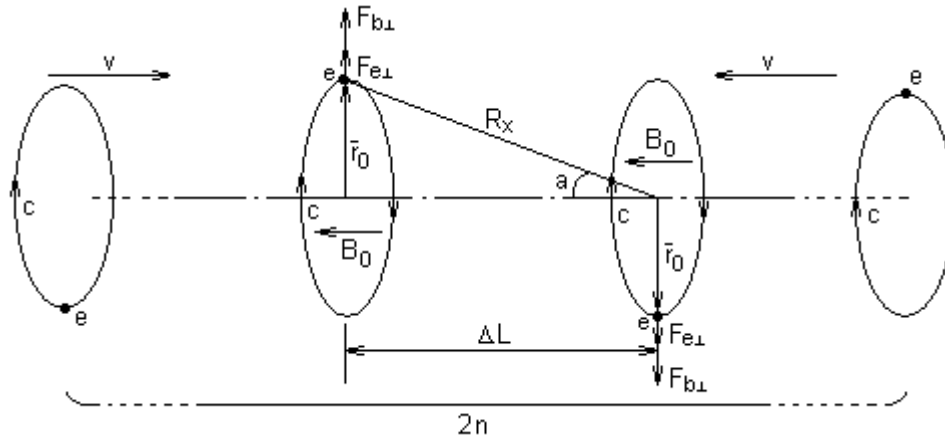

Chart two circular rings current between vertical electric, magnetic field interaction force principle diagrams

Similarly, the Ampere's law, (1.19 ~ twenty) type, the above at the speed of light for circular motion unit positive charge, the magnetic field force $F_{b\perp}$ should be:

$$F_{b\perp} = 2ec \frac{\mu_0 I_0 \bar{r}_0^2}{2\Delta L^3} = \frac{e^2 \bar{r}_0}{2\pi\epsilon_0 \Delta L^3} \tag{1.25}$$

Make (1.24) type of $\Delta L \gg \bar{r}_0$, to simplify the analysis, n took 2, $F_{e\perp}$ simplified to:

$$F_{e\perp} = \frac{8.2963e^2 \bar{r}_0}{4\sqrt{2\pi\epsilon_0} \Delta L^3} \tag{1.26}$$

Make (1.24) in the type of $\Delta L \rightarrow \bar{r}_0$, $F_{e\perp}$ and it can be simplified as:

$$F_{e\perp} = \frac{0.8862e^2 \bar{r}_0}{4\sqrt{2\pi\epsilon_0} \Delta L^3} \tag{1.27}$$

No matter $\Delta L \gg \bar{r}_0$, or $\Delta L \rightarrow \bar{r}_0$, this vertical coulomb repulsion force $F_{e\perp}$ and magnetic force $F_{b\perp}$ can easily stop two series D nuclear head on conflict. In order to more convincing, the electromagnetic field of $F_{e\perp}$ and $F_{b\perp}$ force, the author is taking the maximum. **If we can't effectively avoid $F_{e\perp}$ and $F_{b\perp}$ electromagnetic force in two series D nuclear conflict before bias effect, the cold nuclear collide fusion are mentioned.**

In front of the author in the modern physics classical particle quantization orbital motion model general solution of the book has been proved, all along the straight line type injection of fundamental particles, have fluctuation + spin + precession of the quantization steady state combined motion orbit. This analogy, all of the nucleus, when it in a straight line type injection way movement, its movement direction is the nuclear spin moment of momentum vector direction or reverse direction. In the above inertial guidance cold nuclear direct orientation conflict fusion model design, when D nuclear from accelerator in just jet out or injection before they should be strong magnetic field force constraint determine various D nuclear string spin vector direction is take positive direction, or the reverse direction.

Make nuclear spin moment of momentum is the \vec{J}_m , the conditions within the nucleus of elementary particles for total N, each basic particle of moment of momentum is $\vec{R}_\alpha \times m_i \vec{v}_\alpha$, the theoretical mechanics and (1.2-1), (1.2-2) type, to:

$$\vec{J}_m = \sum_{i=1}^N \vec{R}_\alpha \times m_i \vec{v}_\alpha = \sum_{i=1}^N \frac{\vec{h}}{2\pi} = N \frac{\vec{h}}{2\pi} \tag{1.28}$$

Because in the fusion reaction cavity movement all D nuclear, one of the proton and neutron nuclear core fluctuation velocity are the same, so, if D nuclear string in the nuclear mutual electromagnetic force under the action of $F_{e\perp}$ and $F_{b\perp}$ to each D nuclear moment of momentum vector bias rotation, then this bias rotating angular velocity ω_2 should be equal. And to maintain the angular velocity ω_2 bias rotating gyroscopic moment of inertia $\vec{F}_{m\perp} \times \Delta\vec{L}$, from (1.28) type, to:

$$\vec{F}_{m\perp} = \frac{\vec{J}_m \omega_2}{\Delta\vec{L}} = \frac{N\vec{h}c}{2\pi \bar{r}_0 \Delta\vec{L}} \tag{1.29}$$

Because $F_{e\perp} > F_{b\perp}$, we as long as is $F_{m\perp}$ and $F_{e\perp} + F_{b\perp}$ ratio can judge the possibility of inertial guidance. As long as $F_{m\perp} > F_{e\perp} + F_{b\perp}$, that means D nuclear gyro inertial guidance restoring force $F_{m\perp}$ can overcome D nuclear conflict between electromagnetic field in front of the deflected force $F_{e\perp} + F_{b\perp}$. By (1.25) and (1.26) type, to:

$$\frac{F_{m\perp}}{F_{e\perp} + F_{b\perp}} = \frac{Nhc}{2\pi \bar{r}_0 \Delta L} \cdot \frac{2\pi\epsilon_0 \Delta L^3}{3.9 \cdot 3 \cdot 3 \cdot 2 \bar{r}_0} = \frac{N}{2 \times 3.9 \cdot 3 \cdot 3} \left(\frac{2hc\epsilon_0}{e^2} \right) \left(\frac{\Delta L}{\bar{r}_0} \right)^2 \tag{1.30}$$

On the front type brackets for fine structure constant, its value is 137.0359907. $N = 4$, and $\left(\frac{\Delta L}{\bar{r}_0} \right) \geq 1$ that $F_{m\perp} \gg F_{e\perp} + F_{b\perp}$ value judgment, which using two D nuclear string own super rotation of the gyro inertial guidance characteristics, to achieve nuclear force constraint inertial guidance collide cold fusion is not only feasible, but so far this is almost all mankind to the development and utilization of nuclear fusion can only way!!!

4 specific implementation methods

It has a more comprehensive analysis and simulation demonstrates the nuclear force constraint inertial guidance cold nuclear fusion collide and ion speed dc transformer "invention content. In order to summarize in the invention of the concrete implementation way, we try to 21, 22, 23, 24 of the simplified model or schematic diagram to show cold nuclear collide fusion reaction cavity, ion speed decompression chamber, ion accelerating booster cavity and cold nuclear collide fusion reactor technology path diagram combination.

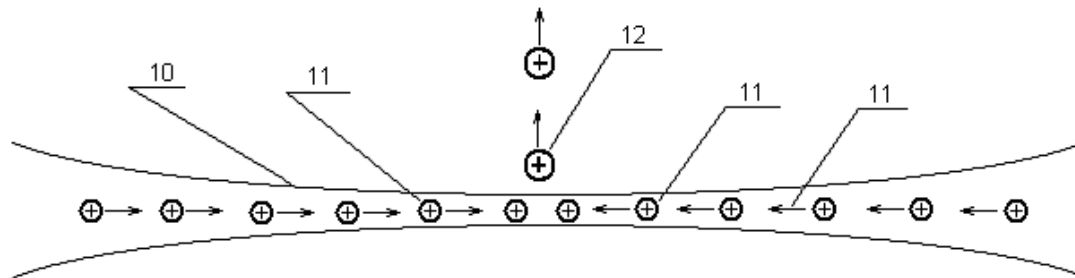

FIG. 21. Nuclear force constraint inertial guidance cold nuclear collide fusion reaction chamber of the working principle diagram 10. Nuclear force constraint inertial guidance cold nuclear collide fusion reaction cavity constraint guidance collide fusion imagine channel 11. D nuclear conflict movement speed and direction 12. Fusion form helium nuclei of the injection speed and direction

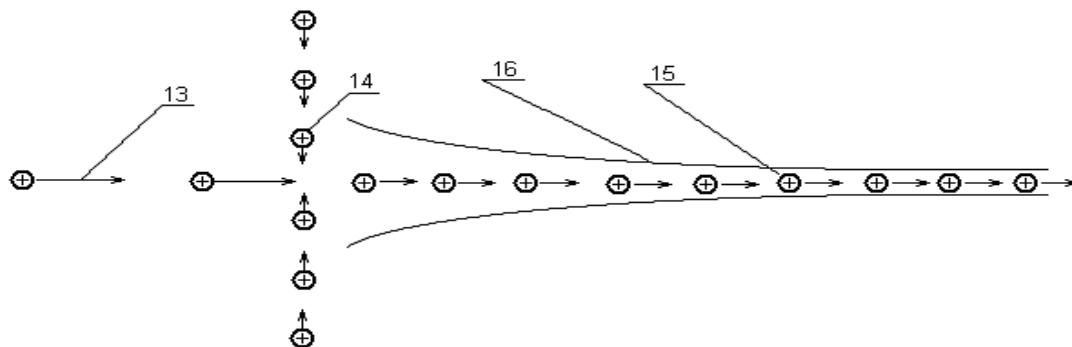

Figure 22. Nuclear force constraint inertial guidance ion speed dc step-down transformer working principle diagram 13. The fusion reaction cavity injection out high energy helium nuclei are movement speed and direction and speed. 14. It is dropping the helium nuclei beam 15. Be mixed speed after the helium nuclei 16. Nuclear force constraint inertial guidance ion speed imagine channel

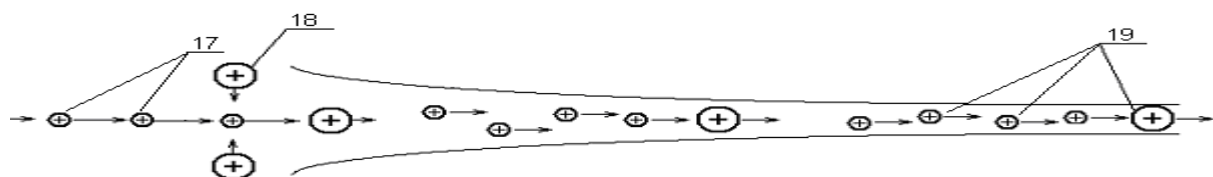

Figure 23. Nuclear force constraint inertial guidance ion speed dc supercharger working principle diagram 17. Proton or helium, lithium ion are beam and high speed movement direction 18. Speed to mix the quality of mercury ion 19. Be mixed speed regulating of protons or helium, lithium ion and mercury ion beam

Below, we force constraint inertial guidance of ion beam control dc transformer mechanical efficiency give brief complement argument.

4.1 «the nuclear force constraint inertial guidance ion speed dc transformer» project design of physical model and theoretical basis

Equipped with two kind of ion quality respectively are: m_1, m_2 , with net electricity for: q_1, q_2 , it ion

beam flow every second for N_1, N_2 . Make to: $K_m = m_1/m_2$, $K_q = q_1/q_2$.

4.1.1 to ion reduction decompression movement

Hypothesis m_1 ion original kinetic energy for the equivalent voltage V_1 , movement speed for v_1 , current for $I_1 = q_1N_1$. M_2 speed ion start-up speed can be neglected. In the beginning and hybrid control section, see figure and the general law of conservation of energy:

$$\left\{ \begin{aligned} V_1 &= \frac{1}{2q_1} m_1 v_1^2 \end{aligned} \right. \tag{1.31-1}$$

$$\left\{ \begin{aligned} \frac{1}{2} m_1 N_1 v_1^2 &= \frac{1}{2} (m_1 N_1 + m_2 N_2) v_2^2 \end{aligned} \right. \tag{1.31-2}$$

In the hybrid control section at the end of the voltage is V_2 , (also can be set to a reference voltage). The two kinds of ion with the same speed v_2 , internal each ion interaction force of the resultant force is 0, each ion keep uniform linear motion. When ions into the reverse pressure reduction movement track section, (the orbital period of electrostatic ion accelerator inversion composition), due to the electric field force of repulsion effect, the quality of small, with a net charge big ion reduction quickly; Quality, net power small ion speed slow. The nuclear force constraint inertial guidance of the integrated effects of single channel in orbit speed movement result, will and energy exchange process. If the last two kind of ion with $v_3 \rightarrow 0$ speed all crowded goal shell voltage cavity, because under the vacuum state, intermediate almost didn't happen energy loss, also need not consider electromagnetic radiation, from the general law of conservation of energy:

By the $I_1 V_1 = I_3 V_3$, because: $I_3 = q_1 N_1 + q_2 N_2$, so:

$$\left\{ \begin{aligned} V_3 &= \frac{I_1 V_1}{I_3} = \frac{N_1 q_1}{N_1 q_1 + N_2 q_2} V_1 = \frac{V_1}{1 + \frac{N_2}{N_1 K_q}} \end{aligned} \right. \tag{1.32-1}$$

$$\left\{ \begin{aligned} \left(\frac{v_1}{v_2} \right)^2 &= \frac{m_1 N_1 + m_2 N_2}{m_1 N_1} = 1 + \frac{N_2}{N_1 K_m} \end{aligned} \right. \tag{1.32-2}$$

If $K_m = K_q = 1$, that is the same ion, the to:

$$\left\{ \begin{aligned} V_3 &= \frac{V_1}{1 + \frac{N_2}{N_1}} \end{aligned} \right. \tag{1.33-1}$$

$$\left\{ \begin{aligned} \left(\frac{v_1}{v_2} \right)^2 &= 1 + \frac{N_2}{N_1} \end{aligned} \right. \tag{1.33-2}$$

Of the same ion in the inverse pressure reduction movement track section, due to the acceleration are the same, as long as ordinary electromagnetic fields focusing tube is ok.

If m_1 is ${}^{19}_9F^-$ ion, m_2 is electronic e^- , due to the $K_m = 34630$. Hypothesis voltage dropping range up to 10^4 times, then:

$$\left(\frac{v_1}{v_2}\right)^2 = 1 + \frac{N_2}{N_1 K_m} \approx 1 + \frac{1}{3.463} = 1.289 \tag{1.34}$$

The analysis results show that the speed of ${}^{19}_9F^-$ ion speed stage changed little. In the reverse pressure stage also continue to electronic plays a key role of the advance.

4.1.2 If it is accelerating booster movement

If it is accelerating booster movement, as long as the direction of the analysis and calculation can be the other way around. Pay attention to at this time, should take the $m_1 \ll m_2$, electronics and individual ${}^{19}_9F^-$ ion is concerned, random chance is too big, the whole line is concerned, it will automatically adjust mixed ion beam overall movement speed, see figure 23. And dropping speed difference only is inverse pressure stage, the quality difference between light ion, nuclear or electronic, must return cycle use.

Because Li, Na, K, Rb, Cs, Fr elements of the evaporation temperature are in $550 \sim 750^\circ\text{C}$ range, Hg element is 357°C . In the vacuum ion condition, may evaporating temperature will be greatly reduced. Captions using proton and Li^+ and Hg^{++} combination of mercury ion, also can consider using H^+ and He^{++} ion and Hg^{++} ion combination. Possible, heavy ion is also considered the use of certain gaseous compound.

4.2 《The nuclear force constraint inertial guidance cold nuclear fusion reactor and ion speed dc transformer》 overall technical way

《The nuclear force constraint inertial guidance cold nuclear fusion collide and ion speed dc transformer》 project master study design scheme, technical way of combination see chart 24.

As for other nuclear or ion generator, ion or nuclear linear accelerator, nuclear fuel supply and energy output automatic balance control system... And other supporting device system, all can accord the main body of the project research design and operation parameters, the corresponding project in the existing technology, equipment and manufacturing process conditions on the basis of optimization and improvement.

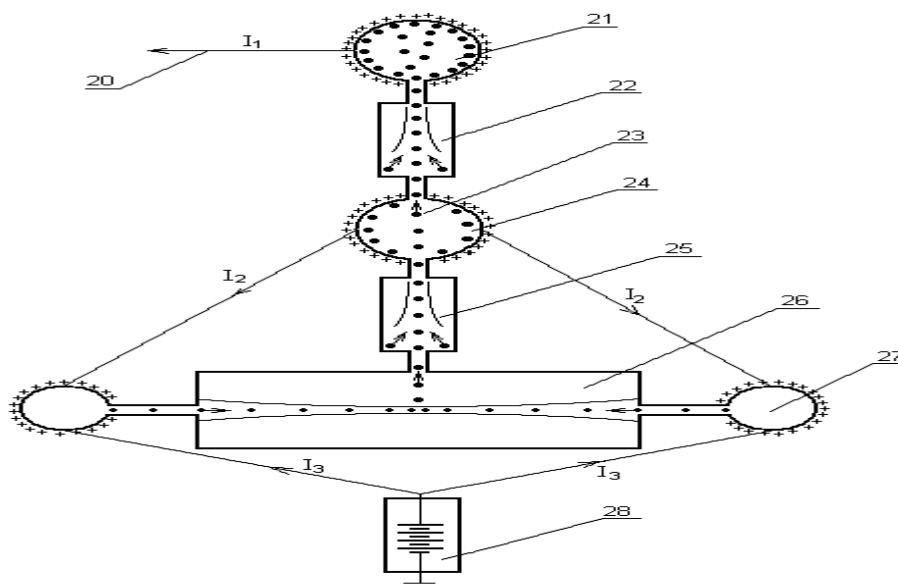

Figure 24. The nuclear force constraint inertial guidance cold nuclear fusion collide and ion speed dc transformer of the overall project design scheme and technical ways combination principle diagram fusion after the transformation of high voltage direct current speed decompression can output 21. It is output power of the high voltage capacitor 22. It is final ion speed step-down transformer 23. It is high energy helium nuclei. 24. Supply electrostatic type linear ion accelerator power supply high voltage capacitor 25. It is primary ion speed dc step-down transformer 26. It is nuclear force constraint inertial guidance cold fusion reaction cavity 27. Electrostatic type linear ion accelerator and. Built-in start power ion speed dc high power supercharger

5 Rights and interests requirements the book

1. The nuclear force constraint inertial guidance cold nuclear fusion collide and ion speed dc transformer invention, whose character is: in cold conditions, set space particular combination of electromagnetic field, according to the light nuclei intrinsic magnetic moment and the electric field, the first two series for fusion of nuclear constraint in the same lines (orbit) inside; Reuse nuclear inherent spin moment of momentum vector formed near the speed of light spin of super rotation gyro inertial guidance characteristics, to overcome coulomb strong base bias effect, achieve collide fusion; According to the similarity of the nuclear force constraint inertial guidance system, the different velocity and energy of the ion beam mixing control, developed ion speed dc transformer, it is cold nuclear fusion collide, issue of motivation and the nuclear power plant start-up fusion and power transfer system of the important equipment, so the merger to apply for a patent.
2. As right request 1 stated Settings space specific electromagnetic fields, is the number or an array of different shapes of charged conductor through the specific space combination set formation of electrostatic field in the background, make its internal produce a set of linear zero field technical methods; Through each a charged conductor are divided into N points conductor, each conductor are separated between electricity medium. The first assumption that a whole conductor surface original net charge surface density is a constant, the surrounding space produce uniform symmetrical power line (field), according to the light nuclei string inherent in electric field, and with other charged conductor common joint patent invention cost required by the group of linear zero field; Then considering the charged conductor and points conductor for electrostatic field mutual induction effect form additional voltage, according to the additional voltage value will be the conductor and points respectively in charge conductor their corresponding total voltage value.
3. Claim 1, 2 mentioned cold fusion reaction cavity, can adjust injection D nuclear series flow, change the conductor internal division conductor charging voltage, can greatly adjustment for fusion of D nuclear set on density and the electric field, so as to achieve the purpose of large adjustment reactor power; Also can be directly through the fusion form helium nuclei jet on both sides of the voltage sensor, direct and D nuclear string beam in linear zero electric field to the entrance of the shunt control electrode connected, avoid two string nuclear flow separately, make each linear zero field within the orbit of the two opposite movement series nuclear collide fusion can go smoothly.
4. Claim 2 mentioned linear zero field design can have a variety of ways, in addition to this paper provides the plate shape charged conductor and a set of 2 ~ N parallel distribution of thin cylindrical charged conductor combination; A group of circular ring charged conductor and a group of fine cylindrical charged conductor outside combination; Also can consider in a group of belt level tabular conductor every two pieces of flat are set up a set of parallel distribution of thin cylindrical charged conductor, form cluster linear zero field group.
5. As right request 1 stated the nuclear force constraint inertial guidance ion speed dc transformer, because there is no fusion of nucleus of jet along vertical direction, but all along the speed regulating the extension

direction of the unidirectional jet, so more easier for group cluster linear zero field parallel cluster design. Such as coaxial a set of circular ring charged conductor and 3 ~ N a parallel set fine cylindrical charged conductor combination, more fine cylindrical charged conductor can along the positive trilateral or is the culmination of four edge shape distribution, but also can be in the form of array or loopy honeycomb combination. So can make group of linear zero field cluster is geometric series surge.

6. As right request 1 stated nuclear beam and ion beam in injection into linear zero field before, should be first to use directional magnetic field to determine spin moment of momentum direction or reverse direction, and must be round ring plate electrode electric field and magnetic field focusing lens to nuclear beam and ion beam focus on comprehensive stack.

7. As right request 1 stated in nuclear beam and ion beam control dc pressure reducer design, can to nuclear beam and ion beam implements continuous multistage depressurization speed control. That is at each level of the speed control of tube end, jet orifice of the end; continue to mass flow in low speed nuclear beam and ion beam, until finally the low level all the big flow nuclear beam and ion beam all into the ball shell metal capacitor, into a certain voltage of dc. So we can omit multiple inversion static type nuclear, ion accelerator.

8. As right request 1 stated to ion speed dc supercharger design, can according to boost multiples, should as far as possible the quality difference between, easy in low temperature excitation generating and more stable ion, such as electronic and F^- and Cl^- anion, protons and Na^+ , K^+ , Hg^{++} ... and combination; Also can consider to meet the conditions of the gaseous compound ion.

9. As right request 1 stated parallel linear zero field direction of the external magnetic field design, should try to adopt the high permeability core of nonconductor material section fill current solenoid, in linear zero field up top department and export of the electromagnet part left for nuclear beam or ion beam injection channel hole.

10. As right request 1 stated the invention of nuclear beam and ion beam acceleration, conflict fusion, mixing speed movement until the power conversion output of all work space, it is in the vacuum suction closed vessel or pipe in the implementation. Therefore, the internal system must also be equipped with a set of vacuum equipment, so that will be formed after fusion helium nuclei, the speed regulation finally complete electrical energy converted into valuable helium gas, constantly out from the working area and collected.